

PO

UNCLASSIFIED

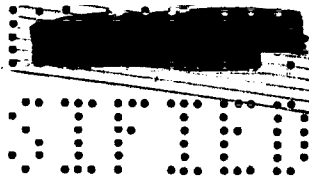

UNCLASSIFIED

LA-472

~~UNCLASSIFIED CONTROLLED~~
~~NUCLEAR INFORMATION~~

LA - 472

C.3



June 25, 1946

This document contains 49 pages.

PREPARATION OF URANIUM METAL BY THE BOMB METHOD

WORK DONE BY:

- R. D. Baker
- B. R. Maynard
- C. Hull
- H. Raich
- A. R. Weiss

REPORT WRITTEN BY:

R. D. Baker

Classification changed to UNCLASSIFIED
by authority of the U. S. Atomic Energy Commission,
Per H. F. Carrall 12-2-57
V. M. Marting
1-13-58

By REPORT LIBRARY

REPRODUCTION
COPY

IS-4 REPORT SECTION

PUBLICLY RELEASABLE

For B. Palatinova FSS-16 Date: 3-1-94
By Mascia CIC-14 Date: 3-25-96
Dallog

UNCLASSIFIED

UNCLASSIFIED

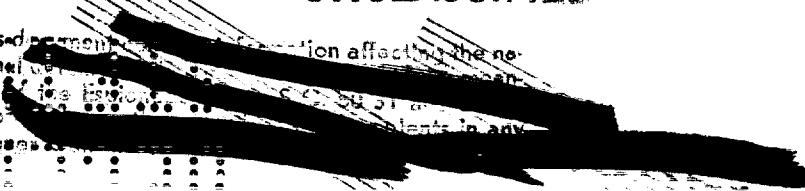

NOV 11 1996



DECLASSIFIED

UNCLASSIFIED

Abstract

This report describes in detail the methods developed at Los Alamos for the preparation of uranium metal by the bomb reduction method. The experimental work on the development of the methods is given for all scales (grams of metal) of reduction. The larger-scale reduction techniques which are described are now used for the routine production of U-235 metal.

ADV 1, 1 1996



LOS ALAMOS NATL. LAB. LIBS.

3 9338 00349 7863

DECLASSIFIED

UNCLASSIFIED

U.S. GOVERNMENT
 PRINTING OFFICE
 1954

UNCLASSIFIED

PREPARATION OF URANIUM METAL BY THE BOMB METHOD

The problem of preparing uranium metal of high purity by the so-called stationary bomb method was started at this laboratory in August, 1948. The objectives of the problem were: (a) the development of small-scale methods (1 to 1000 grams of metal) for the preparation of uranium metal of high purity which could be applied to U-235 metal when it became available; and (b) the use of uranium as a stand-in element for the development of bomb-reduction techniques which might be applied to the preparation of plutonium metal.

At the time the problem was started only the large-scale (25 pounds of metal) reduction technique as developed at Ames, Iowa and the possible use of iodine as a booster was known. This large-scale method was in no way applicable to small-scale work where high yields and high purity were needed. The problem here thus involved the development of refractory crucibles for the reaction, the design of suitable bombs, the investigation of raw materials for the reaction, and the development of techniques for each scale of reduction studied.

Successful bomb techniques were developed in this laboratory for the reduction of uranium tetrafluoride and uranium trichloride with calcium metal on the 1 g, 10 g, 25 g, 250 g, 500 g, and 1000 g (of metal) scales. Most of the work was done on the tetrafluoride, but experiments have shown that the trichloride can be successfully reduced on all the above scales using the same techniques. Experiments on the 10-g scale also showed that U_3O_8 could be reduced with calcium metal using the same procedures as were used with the tetrafluoride. This report deals in the main with the reduction of the tetrafluoride the trichloride being discussed only where essential differences were found to exist.

U.S. GOVERNMENT
 PRINTING OFFICE
 1954

UNCLASSIFIED

UNCLASSIFIED

UNCLASSIFIED

-4-

The following table gives a summary of the optimum conditions for the reduction of UF_4 with Ca in MgO crucibles on the six scales studied.

Nominal Scale	Charge Composition	Heating Time (min)	Max. Crucible Temp. (without charge) °C	Yield in Single Button of Clean Metal
1	0.15 mole I_2 per mole U. 25% Xs Ca. Layers of I_2 + Ca on top and bottom of charge	8	975	94.5
10	0.15 mole I_2 per mole U. 25% Xs Ca	4	770	96.0
25	" " "	6	700	99.0
250	0.2 mole I_2 per mole U. 25% Xs Ca	14	400	99.6
500	" " "	14	400	99.8
1000	0.1 mole I_2 per mole U. 25% Xs Ca.	14	400	99.8

UNCLASSIFIED

UNCLASSIFIED

I. Introduction

The reaction between a metal halide and an alkaline earth metal as used in the so-called bomb reduction is of the thermite type. The fundamental requirement for a successful bomb reduction is that a dense, coherent piece of pure metal giving a yield close to theoretical be obtained. The reaction used for the preparation of uranium metal as reported here is as follows:



When adapting this reaction to the bomb reduction, several considerations must be studied. The melting points of the products of the reaction and the amount of heat liberated by the reaction are important. It is necessary that the reduction be carried out in such a manner that the products of reaction are in the molten state long enough, and that the slag has a sufficiently low viscosity to allow the metal to collect in a coherent piece. In the reduction of the fluoride with calcium, the combination of the melting points of the products and the heat of reaction is not such as to allow for the best collection of metal. Three possible ways of overcoming this difficulty are: (a) supply more heat to the bomb by additional external heating (b) lower the melting point of the slag by the addition of another substance (c) increase the amount of heat liberated in the charge by having a reaction of high heat take place along with the reduction reaction. It is known that external heating must be carried out at such a rate that the products of the reaction do not solidify before separation of the metal has taken place. If this does not happen, it is not possible to collect the metal even by subsequent heating at temperatures well above the melting points of the products.

The application of very rapid heating of the bomb and its contents, especially when applied to the larger solids (25 to 100 g of metal), is very difficult

UNCLASSIFIED

SECRET

SECRET

UNCLASSIFIED

-6-

and impractical. With the small-scale reductions (1 to 25 g of metal), the application of rapid external heating is necessary because of the greater effect^{of}/heat loss to the container. Even with the smaller scales, the rapid external heating is not sufficient to compensate for the combined effects of the heat loss to the container, the heat of reaction, and the melting points of the products of reaction. In the reduction of uranium tetrafluoride, points (b) and (c) are combined by producing by a concurrent reaction a substance which will lower the melting point of the slag while at the same time the reaction supplies additional heat. The reaction used is as follows:



The formation of the CaI_2 supplies additional heat to the charge, and the CaF_2 - CaI_2 slag has a lower melting point than the CaF_2 alone. In the case of the trichloride, iodine is used in the larger-scale reductions to supply additional heat more than to lower the melting point of the $CaCl_2$ slag. The use of an inert atmosphere, such as argon, in the bomb aids in the separation of the slag from the metal and gives a much better formed piece of metal. This is probably due to the lowering of the viscosity and/or the melting point of the slag by the elimination of calcium oxide and calcium nitride. If air or nitrogen is used, much of the slag freezes on the liner walls, and the metal button is apt to be poorly formed and difficult to clean.

A knowledge of the starting temperatures of the reactions and reaction mixture is important in the development of a successful heating or firing procedure for a bomb reduction. A method was developed in this laboratory for determining the starting temperatures of various reactions under conditions similar to those used in the actual reductions. This determination was carried out on the 10-g scale using the same type bomb

UNCLASSIFIED

UNCLASSIFIED

and crucible (liner) as used for the actual reduction. A thermocouple is placed against the inside wall of the liner, the charge placed in the liner, and the bomb closed. (The thermocouple leads are sealed and insulated through the bomb lid.) The bomb and its contents are then heated under conditions similar to those used for an actual reduction, time-temperature data being taken from the thermocouple in the bomb. At the time the charge fires there is a large increase in temperature per unit time. The values thus determined are given, along with the calculated heats of reaction, in Table I.

TABLE I

Starting Temperatures for Halide-Calcium Mixtures

Mixture 25% Xs Ca	Heat of Reaction (ΔH) K. cal/mole of halide	Starting Temp. °C
UF ₄ + Ca	-126.0	515
UCl ₃ + Ca	- 73.0	649
I ₂ + Ca	-128.5	398
UF ₄ + 0.1 mole I ₂ + Ca	-138.9	410

Data from - Brchowsky and Rossini, The Thermochemistry of Chemical Substances, Reinhold Publishing Co. (1936)

It should be noted that in addition to supplying more heat and a lower melting slag that the I₂ + Ca reaction determines the starting temperature of the reaction mixture. It has been found that variations in the amount of iodine used in the charge does not change the starting temperature of the reaction mixture.

The container in which the reaction takes place is a steel bomb with a liner of refractory material. This refractory liner is a very important consideration in bomb reduction development. The following points

UNCLASSIFIED

UNCLASSIFIED

are important when considering a reduction liner.

(a) Reaction between the electropositive reductant, the reduced metal, or the slag produced should be as small as possible.

(b) It should be sufficiently impervious to retain the reaction products, and should be of such purity as not to contaminate the metal produced.

(c) It should be capable of withstanding the thermal shock of the rapid heat evolution accompanying the reaction.

(d) If a given rate of heating of the reduction charge is to be repeated on every run, the thermal conductivity of the liner must be reproducible also, the rate of heat transfer from the bomb to the liner must be duplicable; therefore, the fit of the liner to the bomb must be controlled.

The most satisfactory liners for uranium reductions on all scales have been found to be prefired, magnesium oxide crucibles. The liners used will be discussed in more detail under the various scales of reduction.

II. Raw Materials

1. Calcium

The choice of calcium metal used in the thermite reaction under consideration is of primary importance. The reductant must be low in light-element impurities so as not to contaminate the uranium metal produced. It must also be free of oxide and low in nitrogen. It has been found that calcium containing 0.40% N₂ or less is satisfactory for reductions of the tetrafluoride when the bomb is argon-filled, while with air-filled bombs the nitrogen content must be 0.04% or less. If the nitrogen content is too high, the metal buttons are poorly formed and the yield of metal tends to be lower. The calcium used in the work reported here was redistilled-electrolytic calcium manufactured by the Electro-Metallurgical Corporation.

UNCLASSIFIED

UNCLASSIFIED

The calcium was received as carrots. These were ground or sheared to -3, +4 mesh (1/4" pieces), after which they were ground in a Wiley mill and screened, the -20, +80 mesh fraction being used. This grinding and screening removes much of the oxide and leaves a clean shiny product. The ground calcium was stored under argon. The 1/4" pieces of calcium have been used in the larger-scale reductions (500 to 1000 g of metal) with success, but the ground calcium is necessary for the smaller scales. The grinding and screening operation is recommended for calcium used for all scales because of the oxide that is removed and because of the better mixing of the calcium with the fluoride and iodine. A typical analysis of the calcium used is given in Table II. The nitrogen specifications have been given above.

TABLE II

Analysis of Ca Used

<u>Element</u>	<u>ppm</u>
B	<0.5
Al	<10
Mn	<10
Mg	<1000
Fe	50

It has been found that calcium containing 400 to 500 ppm of Al, 400 to 500 ppm of Mn, and 1% of Mg contaminates the uranium metal with 100 to 125 ppm of Al and Mn, lowers the average yield for large-scale reductions by 0.2% and gives a poorly formed button as compared with those obtained when the "standard" calcium metal is used. It has also been found that redistilled calcium which is packed and shipped as turnings is usually too high in nitrogen to be used in the reduction processes described.

UNCLASSIFIED

UNCLASSIFIED

-10-

2. Tetrafluoride

The UF_4 used for all experimental work was of commercial grade prepared for the Manhattan District Project by Mallinckrodt Chemical Works. A typical chemical analysis of the fluoride is given in Table III.

TABLE III

Analysis of Uranium Fluoride Used

<u>Element or Compound</u>	<u>Percent or ppm</u>
UO_2	0.29 %
UO_2F_2	2.08 %
H_2O	380 ppm
C	200 "
Li	< 2 "
Be	< 0.05 "
B	< 0.5 "
Na	< 5 "
Mg	5 "
Al	< 20 "
Si	1 "
Ca	100 "
Fe	20 "

The untamped bulk density of the fluoride was 2.8 g/cc, and the particle size was -100 mesh. The effects of bulk density and particle size on the reduction of the tetrafluoride are not known to be very pronounced, but a high bulk density and a small particle size are of value in mixing and putting the charge into the bomb liners. This is especially true for the small-scale reductions. The UO_2 and UO_2F_2 contents given in Table III give the fluoride an oxygen content of 0.25%. Experiments on the tolerable oxide

UNCLASSIFIED

UNCLASSIFIED

content of tetrafluoride have been run and are described in the section on the 250 g scale reduction. The amount of oxide in the fluoride becomes more important the smaller the scale of reduction. In order to obtain consistent high yields on all scales, the fluoride should be 99+⁴/₁₀₀ converted from the oxide.

Special fluorides prepared at Site X and by Group CM 16 were employed in preparing U-235. The analyses of these fluorides were nearly the same as given in Table III. The bulk density of the fluoride prepared by CM 16 was low; being 1.8 g/cc as compared with the 2.6 to 3.0 g/cc density of the fluoride prepared at Site X. The low bulk density had no effect on the reduction but it was difficult to get the full charge into the reduction liner used.

3. Iodine

Reagent-grade, redistilled iodine manufactured by Mallinckrodt Chemical Works was used. For the small-scale reductions (1 to 25 g) it was ground to -30, +80 mesh, but was used as received for the larger-scale reductions.

III. 1-, 10-, 25-gram (of Metal) Scale Reductions

1. General

(a) Apparatus: The apparatus consists, in general, of a bomb or external container with a pre-fired refractory liner for the charge, and a high-frequency converter and furnace to heat the loaded bomb under controlled conditions. Fig. I is a photograph of the bombs and liners used. Fig. II gives cross-sectional drawings with dimensions of the bombs and liners. The bombs are machined from cold-rolled steel rod and have threaded caps with a lip on the inside which makes a seal with the copper gasket held in a groove in the body of the bomb. The screw in the cap of the bomb is to enable filling the loaded bomb with an inert gas.

UNCLASSIFIED

UNCLASSIFIED

-12-

The most satisfactory liners were found to be pre-fired crucibles made of magnesium oxide. The MgO used was an electrically fused product (Vitrafrax) ground to pass a 300-mesh sieve. Unfortunately, this material, made from mined magnesite, is no longer available. Later shipments of powder from the same supplier were found to behave quite differently. This powder will be discussed after the use of the mined magnesite is described.

The mined magnesite had the following analysis:

Fe	0.057
SiO ₂	1.58
R ₂ O ₃	0.39
CaO	0.50
B	20 ppm

The liner was formed in a graphite mold using either a graphite or metal plunger. The procedure was to jar a bottom layer of MgO in the mold center the plunger (which determined the shape of the inside of the liner) in the mold, and add powder in small amounts, the mold being jarred on the beach after each addition. When the height of the liner was reached, the plunger was carefully removed. The formed liner was then fired in the mold to 2200°C by induction heating. This firing took about twenty minutes. After cooling, the liner was removed from the mold. Liners made in this manner, and with the mined magnesite, were hard and dense, and were satisfactory for fluoride reductions. They were, however, too porous to be used for chloride reductions. The "vitrification" of the liner at still higher temperature for use in both fluoride and chloride reductions was accomplished as follows: A large MgO crucible (4" OD, 3.5" ID and 6" high) which had been fired to 2300°C was placed in a graphite crucible which was 6" OD, 5" ID and 9" high. The cover of this crucible had a center vent hole and a gyprometer sight tube

UNCLASSIFIED

UNCLASSIFIED

-13-

at an angle of 45 degrees. The liners prepared as above were placed in the large MgO crucible which was covered with a MgO lid. The graphite crucible was heated in a 7" I.D. induction furnace powered by a 20-KW Ajax converter. The "vitrification" cycle was to heat the liners to 2300°C in 1.5 hours and hold at this temperature for thirty minutes.

Calcium oxide liners were also made and vitrified by this method, except that the first firing temperature was 1700°C and the vitrification conditions were 2100°C, for thirty minutes. Electrically fused CaO was used. The CaO liners made by this method were very dense and non-porous, but were inferior to the MgO liners for reduction, probably because of a reaction between the slag and the CaO. Thoria and zirconia liners were also prepared by the hand tamping method and will be discussed under the reduction scales in which they were used.

As stated above, the mined magnesia was later substituted by a product which could not be used for the making of liners by hand tamping of the dry powder. The use of the powder was taken over by Group CM-7. A method was developed using machine tamping and pressing of the moist powder to form the liner. The formed liner was then dried and fired using the same "vitrification" cycle as described above. The liners obtained were satisfactory for both chloride and fluoride reductions. As can be seen from the following analysis of the powder, the boron content was high, and the metal made in the liners ran higher in boron than the metal made in liners of the mined magnesite.

Fe	0.17%
SiO ₂	2.35
R ₂ O ₃	0.5%
CaO	0.5%
B	500 ppm

UNCLASSIFIED

UNCLASSIFIED

-14-

(b) Loading of the Bomb: The halide is mixed with the reducing metal and iodine in a closed bottle and the mixed charge poured into the liner, covered with the refractory lid, and the bomb cap is screwed on and tightened. The closed bomb is then placed in a vacuum jar (see Fig. 3), through the lid of which a screw driver passes by means of a Wilson seal. The screw in the cap of the bomb is then run out, it being held by means of a clip on the screw driver. The jar is then twice evacuated and twice filled with argon, the screw replaced and tightened in the cap, and the bomb removed from the jar ready for firing.

(c) Firing of the Charge: In the firing of the reaction mixture a controlled and reproducible rate of heating is necessary, and a knowledge of the top temperature reached is important. This is especially true in the case of the small-scale reductions where the heat generated by the reaction itself is not sufficient to keep the reaction products in the molten state long enough for the metal to collect in one coherent piece. The rate of heating of the reaction mixture is also important because if the temperature rise is not fast enough through the firing temperature, the products may solidify, and subsequent heating to temperatures above the melting points of the products will not coagulate the metal satisfactorily. A method of heating the bombs was developed where the rate of temperature rise and top liner temperature (without the charge) reached were known and could be varied.

Data for the above method of firing were obtained by taking time-temperature data on the inside of the liner without a charge. Fig. 4 is a graph showing these data for MgO liners on the 1-g, 10-g, and 25-g scales. These rates of heating have been found best for firing the bombs, having been ascertained in most cases by trying both slower and more rapid rates of firing. The converter, coil, location of bomb, etc., used to obtain these curves will be given in the discussions of each scale. The use of these

UNCLASSIFIED

UNCLASSIFIED

curves can be explained with an example. Consider the 1-gram scale bomb with a MgO liner. A reduction of UF_4 with Ca is to be run. It has been found that firing to a liner temperature of $975^\circ C$ at the rate given by curve 1 is satisfactory (not considering the heat of reaction). The time of heating would be 8 min (see Fig. 4).

(d) Unloading of the Bomb and Cleaning of the Metal: The liners are usually easily removed from the bomb. They are then broken open and the button of metal removed. Slag and excess calcium which may be on the metal is removed by placing the button in a 1:3 acetic acid solution. After pickling, the button is washed in water and dried in acetone.

2. 1-gram Scale Reductions

The bomb and liner for this scale of reduction have been described. Curve 1 of Fig. 4 gives the heating rate which was found to give the most satisfactory and consistent reduction results. A 7.5-KW high-frequency Lepel converter was used with the following coil: 3" ID, 2" high, and 7 turns of $1/4"$ copper tubing flattened to a thickness of $1/8"$. The converter settings were as follows:

Coarse Inductance Setting: Left M, Right M

Fine Inductance Setting: 18

Power Set: 6

The bomb was centered in the coil.

The charge composition was studied with respect to the amount of iodine used; variations from 0 to 1.36 mole I_2 /mole U being tried. The optimum charge composition for all methods of firing was as follows: 0.15 mole I_2/U with 25% excess Ca over that required to react with the fluoride and iodine. The charge also consisted of a layer of 0.15 g $I_2 + 0.02$ g Ca at the bottom and a similar layer at the top of the charge. The use of

UNCLASSIFIED

UNCLASSIFIED

-16-

these $I_2 + Ca$ layers was important the same effect could not be accomplished by adding the corresponding amount of I_2 and Ca to the reaction mixture itself. It was found that amounts of I_2 below the 0.15 mole ratio were poor but that amounts above this value did not aid in the reduction but only increased the amount of slag absorption and, in general, the metal buttons were not as well formed. The heating rate used was found to be critical a summary of the important variations studied being given in Table IV. The charge was the one given above. Magnesium oxide liners fired at 2200°C in graphite were used.

TABLE IV

Entry	No. of runs	Heating Time	Liner Temp. Without Charge	Yield %			Remarks
				Max.	Min.	Av.	
1	29	8 min.	975°C	97.0	90.0	94.5	All well formed buttons slag down well.
2	2	3 min.	875°C	94.0	94.0	94.0	Well formed buttons, slag down fairly well.
3	3	1 min.	550°C	95.0	90.0	92.0	" " "
4	10	45 sec.	1380°C	96.0	25.0	82.0	Buttons not as well formed slag absorption high.
5	5	45 sec. held at 1380°C for 2 min.	1380°C	95.0	52.0	75.0	" " "

Entry 1 gives the data obtained using the most reliable procedure found that is heating for 8 min. at the rate given in curve 1, Fig. 4. Entries 2 and 3 (curve 1 Fig. 4 used) show that good results may be obtained by using lower top liner temperatures. However, the slag does not run down over metal button as well, and the yields are not quite as high. It is believed

UNCLASSIFIED

UNCLASSIFIED

-17-

that these lower temperature firings are not as reliable as the 975°C procedure. It should be noticed that the rate of firing through the starting temperature of the reaction (410°C) is the same for the first three entries in Table IV, the only differences being in the top temperatures reached. Entries 4 and 5 are for much more rapid rates of heating and higher top temperatures. These heating rates gave lower yields, poorly formed buttons, and much higher slag absorption by the liner. Some experiments were run where the time of heating to the starting temperature was 3 minutes and then the heating rate increased so that a liner temperature of 975°C was reached in an additional 5 minutes. This heating or firing procedure gave very low yields and sometimes only powdered metal was obtained. From the above discussion it should be noticed that the rate of heating through the starting temperature is very important that the amount of iodine used is not critical above 0.15 mole I₂/mole U and that the use of the I₂ + Ca layers is important for a successful reduction of UF₄ on the 1-gram scale.

A photograph of a 1 gram reduction button is given in Fig. 5. A typical analysis of the metal made on this scale is as follows (values in pp.): Be, <0.4; B, <0.2; Mg, 25; Si, 1.5; and Fe, 50. The scale-range of the reduction charge using the 1-gram bomb, liner, charge composition, and heating cycle as described is from 0.5 to 1.5 grams of metal. Reductions of UF₃ using the same charge and firing procedure gave yields comparable to those of UF₄ reductions. The same firing procedure was used for successful reductions of UCl₃ with Ca. The "vitrified" MgO liners were necessary for the chloride reductions, and no iodine was used in the charge.

Profired ThO₂ liners of the same design as the MgO liners were used and found to give very poor results, the yields being from 0 to 73%. Several charge compositions and firing procedures were tested, but no successful

UNCLASSIFIED

UNCLASSIFIED

-18-

reductions were made using ThO_2 for the refractory liner. The yields obtained using vitrified CaO liners were from 80 to 90%, and the metal buttons were not as well formed as with MgO liners. There was much slag absorption, probably due to a reaction of the slag with the CaO liner.

3. 10-Gram-Scale Reduction

The bomb and liner for this scale of reduction have been described. Curve 2 of Fig. 4 gives the heating rate which was found to give the most satisfactory and consistent results. A 3-Kw high-frequency Ajax converter was used with a standard Ajax coil: 4" ID and 4" high. The bottom of the bomb was located $1/4$ " above the bottom of the coil. The converter was run at full power (angle 0).

The charge composition was studied with respect to the amount of iodine used variations from 0 to 2 moles I_2 /mole U being tried. It was found that the slag formed with no iodine present had too high a melting point and viscosity only beads of metal being obtained. Iodine ratios above 0.15 moles I_2 /mole U did not improve the reduction but only increased the amount of slag absorbed by the liner. When the slag absorption is high, there is a decrease in the yield, due to some metal being absorbed with the slag. The optimum charge composition was found to be 0.15 moles of I_2 /mole U with 25% excess Ca over that required to react with the fluoride and iodine. The use of layers of $\text{I}_2 + \text{Ca}$ as in the 1 gram reduction was found to be of no value. Much of the work on the 10 gram scale was carried out using air-filled bombs. When air was used the slag froze on the walls of the liners leaving the button with a slightly rough top. When argon was used, the slag collected above the well formed button in one compact piece. The yields obtained using air or argon did not vary appreciably.

The firing or heating of the loaded bomb was studied, the most

UNCLASSIFIED

UNCLASSIFIED

-19-

satisfactory rate being that given by curve 2, Fig. 4. The heating time was 4 minutes, giving a top-liner temperature (without the charge) of 770°C. Successful reductions were made using the same rate of firing as above with a top-liner temperature of 450°C however, the results were not as consistent as when a liner temperature of 770°C was used. More rapid rates of firing were studied, since it was found that the collection of metal was poor and that the results could not be duplicated. A series of experiments were run where the loaded bombs were held at temperatures of 500°, 300°, and 200°C in a crucible furnace and then removed and heated in the induction coil. The charges which were heated at 500°C fired about one-half the time, if they did not, heating to 770°C in the induction coil did not start the reaction. Those that did fire in the crucible furnace gave very poor collection of metal. The charges which were heated at 300°C and 200°C and then fired in the induction coil gave low yields and poorly formed buttons. Examination of the charges which had been heated to 300° and 200°C showed that a layer of CaI_2 had been formed on the Ca particles. This layer of CaI_2 probably lowers the rate of reaction, thus allowing more heat to be dissipated to the liner and bomb before the reaction is complete, causing poor collection of metal.

The most satisfactory liners for the 10-gram-scale reduction were found to be of prefired magnesium oxide prepared as previously described. Liners fired at 2200°C in graphite were used for fluoride reductions, but the "vitrified" liners were found necessary for chloride reductions. Prefired ZrO_2 liners made by the hand-tamping method and fired in graphite to 1800°C were tested and found to give yields of 40 to 70% with poorly formed buttons. The metal obtained from these liners contained 0.20% Zr. The main reason for the failure of these liners is probably due to the fact that the Ca metal reduced the ZrO_2 , thus lowering the efficiency of the $\text{Ca} + \text{Ca}$ reaction, and also

UNCLASSIFIED

UNCLASSIFIED

-20-

raising the melting point and/or the viscosity of the slag. Prefired ThO_2 liners made in the same way and fired to 1900°C in graphite were found to be very unsatisfactory, giving very poor collection of metal. The reason why ThO_2 does not make a good liner is not clear. Loose magnesium oxide liners made by hand-tamping the powder into the bomb were found to be very poor because of the high slag absorption and the reaction and mixing of the slag with the MgO powder. Prefired CaO liners made as previously described were tested and found to give yields of 80 to 90%. The slag absorption was high, probably because of a reaction of the slag with the CaO . Bombs of iron, copper, and uranium with the same size bore as the MgO liners were tested without liners. The metal formed alloyed with the bomb walls and bottom, thus giving very poor reductions.

The procedure used for the 10-gram reductions of UF_4 as outlined above was found to be satisfactory for reductions of both UCl_3 and UI_4 with Ca , except that the addition of I_2 was not necessary. The UI_4 is hygroscopic and decomposes at room temperature. It was therefore necessary to work with the iodide at dry-ice temperatures and in dry air.

The average yield obtained in the reduction of UF_4 with Ca as described above was 96%. A photograph of a 10 gram as-reduced button is given in Fig. 5. A typical analysis of metal made on this scale is as follows (values in ppm): Be, 0.1; B, 0.2; Mg, 5; Si, 3.5; Ca, 20; and Fe, 100. The scale-range for the reduction charge using the 10-gram bomb, liner, charge composition, and heating cycle as described is from 5 to 12 grams of metal.

4. 25-Gram-Scale Reductions

The bomb and liner have been described. Curve 3 of Fig. 4 gives the heating rate which was found to give the most satisfactory and consistent results. A 3-KW high-frequency Ajax converter was used with a standard Ajax coil 4" ID and 4" high. The bottom of the bomb was located $1/4$ " above the

UNCLASSIFIED

-21-

bottom of the coil. The total heating time was 6 minutes to a top-liner temperature (without the charge) of 700°C (see curve 3, Fig. 4). The converter settings for this heating cycle were; angle 25 for 2.5 minutes and angle 0 for 3.5 minutes. The optimum charge composition was found to be 0.15 mole I_2 /mole U and 25% excess Ca over that required to react with the fluoride and iodine. The average yield for this scale of reduction was 99%, the buttons being well formed (see Fig. 5). The liners used were prefired MgO fired at 2100°C in graphite or "vitrified" as previously described. The scale-range of the reduction charge using the 25 gram bomb, liner, charge composition, and heating cycle as described is from 10-30 grams of metal.

IV. 250-, 500-, 1000-Gram (of Metal) Scales:

I. General

(a) Apparatus: The apparatus consists, in general, of a bomb or external container with a pre-fired refractory liner for the charge, and a high-frequency converter and furnace to heat the bomb under controlled conditions. Two types of bombs have been used for reductions on the 250- and 500-gram scales; one with a double flange and one with a solid bottom. The two-flange bombs are desirable where the liners do not fit well and may stick in the bomb after firing. Fig. 6 and 6 (a) are photographs of these 250-gram bombs and liners, while Fig. 7 and 7 (a) are cross-sectioned drawings with dimensions. Fig. 8, 8 (a), 9, 9 (a), are for the 500-gram scale bombs and liners. Fig. 10 and 11 are for the 1000-gram scale. All bombs are made of cold-rolled steel. The screw and gasket in the lid of the bomb is to enable filling the loaded bomb with an inert gas. The thermocouple well is for the purpose of following the heating cycle. The lids or covers of the bombs have a lip which is forced into the annealed copper gasket.

UNCLASSIFIED

UNCLASSIFIED

-22-

The most satisfactory liners were found to be pre-fired crucibles made of electrically fused magnesium oxide. Only a few liners used were made by the hand-tamping method described in the small-scale section. Most of the liners were made at M.I.T. or by Group CM-7. The powder used by M.I.T. had the following analysis:

Fe	0.02%
SiO ₂	2.00
R ₂ O ₃	0.23
CaO	0.69
B	30 ppm

The analysis of the powder used by Group CM-7 was as follows:

Fe	0.17%
SiO ₂	2.35%
R ₂ O ₃	0.56%
CaO	0.94%
B	300 ppm

The boron content of this powder is higher and, as will be discussed later, the boron content of the metal made in these liners was higher than that of metal made in M.I.T. liners. Some liners were received from M.I.T. which were made of powder containing 4% SiO₂. These liners, even though fired at high temperatures, showed very high slag absorption, and the metal obtained was high in Si (1000 ppm) and Mg (250 ppm).

Briefly, the method used at M.I.T. for the manufacture of the liners was as follows: The magnesium oxide was mixed with 7% water and tamped and pressed into steel dies. The formed liner was then extruded from the die, dried, and fired in a gas furnace at 1700°C. for three hours. The only

UNCLASSIFIED

UNCLASSIFIED

-23-

essential difference from the above procedure and that used by CM-7 was that the dried liners were induction fired to 2100°C using graphite as a heater. With both methods the resultant body was hard and had a porosity of less than 22%. Liners fired by induction to 2300°C for "vitrification" were found to crack due to thermal shock when the reduction reaction took place. Prefired CaO liners made at Ames, Iowa were tested on the 250 gram scale and found to be inferior, probably because of the reaction between the slag and CaO.

(b) Loading of the Bomb: The halide is mixed with the reducing metal and iodine in a closed bottle and the mixed charge poured into the liner, covered with the refractory lid, and the space between the liner and bomb wall and above the liner lid and gasket groove filled with 40 mesh electrically fused magnesia powder. The gasket groove is then brushed free of magnesia and the annealed copper gasket put in place. The bomb lid is then bolted on. A stopcock assembly (Fig. 12) is then screwed into the hole in the bomb lid and the bomb twice evacuated and filled with argon. The stopcock assembly is then removed and quickly replaced with the screw and copper gasket.

(c) Firing of the Charge: The essential difference between the firing technique used for the larger scale reductions and that used for the small scales is that the large-scale charges are heated just to the starting temperature and the heating stopped, while on the smaller scales the heating is continued past the starting temperature of the reaction mixture. The heating of the bomb and its contents to the starting temperature of the reaction mixture is very important. It has been found in this laboratory that the charge requires a definite preheat period before the starting temperature is reached. If the bomb is heated rapidly, the reaction starts at the surface between the charge and liner, while the center of the charge is at a much lower temperature. In this case more of the heat of reaction is dissipated in heating the charge, thus allowing the products to solidify more rapidly than if a preheat is used.

UNCLASSIFIED

UNCLASSIFIED

-24-

If the preheat period is too long, the calcium particles are coated with a layer of CaI_2 (see 10-gram scale) which presumably lowers the rate of reaction with the fluoride. This allows more heat to be dissipated to the liner and bomb before the reaction is complete, thus again causing poor collection of metal. The heating or firing procedures used for the 250-, 500-, and 100-gram scales are the same, and were arrived at by experiment, using several different heating cycles to locate the optimum conditions. When developing a heating cycle, three thermocouples are placed on the inside surface of the liner, one near the top, one at the center, and one on the bottom. The temperature of the liner can then be correlated with the temperature of the outside thermocouple well. It is important that the bomb be located in the coil so that the entire length of the liner heats at nearly the same rate ($+75^\circ\text{C}$). For example, if at the time of firing, the bottom portion of the liner is well below the firing temperature, the metal button is poorly formed and a lower yield is obtained.

In the actual firing procedure used for the 250, 500, and 1000-gram-scale reductions, the loaded bomb is placed in an induction furnace which is powered by a 20-KW high-frequency Ajax converter. The 250- and 500-gram bombs are placed in a 7" ID, No. 312 Ajax furnace so that the bottom of the bomb is 1" above the bottom of the coil. The 1000-gram bomb is placed in a 9" ID, No. 313 Ajax furnace so that the bottom of the bomb is 1" above the bottom of the coil. The coils are protected by a silica sleeve which fits on the inside of the coil. After the bomb is placed in the coil, the thermocouple (Chromelalumel) is then placed in the well on the bomb and the heating cycle given in Table V followed. The liner temperature given is an example and will vary $+75^\circ\text{C}$ depending on the fit of the liner. The heating cycle for the thermocouple well is one recommended for the bombs used however, if different bombs, liners, etc. were used, the liner temperature data should be duplicated and not the

UNCLASSIFIED

UNCLASSIFIED

-25-

01110
01110

thermocouple-well cycle. When the charge reaches the starting temperature, which is between 12 and 15 minutes, there is a sudden increase in temperature with time. When the increase occurs, the power is turned off and the bomb is allowed to stand in the coil for about five minutes before cooling to room temperature in front of a fan. Fig. 13 is a photograph of the firing crucible, coil, and converter used.

TABLE V

Heating Cycle for 250-, 500-, and 1000- Gram Bombs

<u>Time Min.</u>	<u>Thermocouple Well - °C</u>	<u>Liner Temperature °C</u>
1	110	25
2	200	47
3	280	64
4	360	102
5	400	135
6	425	164
7	450	211
8	475	252
9	500	279
10	525	320
11	550	347
12	575	381
13	600	416
14	625	442
15	650	470
16	674	500

UNCLASSIFIED

01110
01110

UNCLASSIFIED

-26-

SECRET
 CONFIDENTIAL

(d) Unloading the Bomb and Cleaning of the Metal: After the lid is removed, the outside of the bomb is tapped with a hammer until the contents of the bomb can be poured out. Slag and calcium which may be on the metal is removed by placing the button in a 1:3 acetic acid solution. After pickling, the button is washed in water and dried in acetone.

2. 250-Gram-Scale Reductions

The bombs and liners for this scale of reduction have been discussed. Much of the work on this scale was carried out using air-filled bombs rather than argon-filled bombs. When air was used in the bomb, the slag froze on the walls of the liner, and the button of metal had a rough top which was difficult to clean. With argon, the slag collected in one piece above the metal button, which had a smooth, clean top. The yields obtained in air-filled and argon-filled bombs were not appreciably different.

When the atmosphere in the bomb was air, the optimum charge composition was found to be 0.40 mole I_2 /mole U with 25% excess Ca over that required to react with the fluoride and iodine. Iodine ratios as low as 0.15 mole I_2 /mole U gave satisfactory reductions, but the results were not as reproducible. Reductions using less than 0.15 mole I_2 were not satisfactory, while I_2 ratios greater than 0.40 mole I_2 /mole U were of no advantage. When argon-filled bombs were used, the optimum charge was found to be 0.20 mole I_2 /mole U with 25% excess Ca over that required to react with the fluoride and iodine. Iodine ratios as low as 0.10 mole I_2 /mole U gave satisfactory reductions, but the results were not as consistent as with 0.20 mole I_2 . Reductions using less than 0.10 mole I_2 were not satisfactory, while more I_2 was of no advantage and the metal obtained was higher in magnesium.

UNCLASSIFIED

SECRET
 CONFIDENTIAL

UNCLASSIFIED

-27-

.

A study, using air-filled bombs, was made of the UO_2 content of the UF_4 . The experiments were made by mixing UO_2 with the standard UF_4 . It was found that the yield of coherent metal was not affected for UO_2 contents as high as 4.22 (0.5% O_2). A decrease in yield of only 0.9 percent was obtained using 8.44 percent UO_2 (1.00% O_2). Larger amounts of UO_2 gave poor reductions, the yields being low and the metal buttons poorly formed. Experiments were also run using fluorides which had low conversions from the oxide. Argon-filled bombs were used. It was found that fluoride of 98.7% conversion gave satisfactory reduction results; the yield from 93.7% converted fluoride dropped 0.50% and the button was poorly formed. Fluorides 91.7% converted from the oxide gave only powdered metal.

The firing or heating procedure used for this scale of reduction has been given and described. The procedure was arrived at by running experiments using different rates of heating it being found that the preheat period was very important, and that heating the bomb after the reaction had started was of no advantage. Experiments were also run using a resistance furnace for heating the bomb and its contents. It was found difficult to obtain and duplicate the desired preheat rate, and much trouble was encountered with the copper gaskets leaking iodine. This was due to the gaskets being heated more than with the induction heating.

The average yield for the 250-gram-scale reduction using the standard procedure as outlined was 99.6%. An average analysis of the metal obtained from M.I.T. liners was as follows (values in ppm): Be, <0.2; B, <0.2; Mg, 15; Na, 5; Al, <5; Si, 9; Fe, 10; C, 120; and Ca, 20. The boron content of metal made in liners from Group CM-7 ran somewhat higher, the value being from <0.2 to 1 ppm. This was, as given in the liner discussion, due to the fact that the magnesium oxide powder used by CM-7 was higher in boron. A photograph

UNCLASSIFIED

UNCLASSIFIED

-28-

CONFIDENTIAL
 [REDACTED]

of a 250-gram button is given in Fig. 14.

The scale-range of the reduction charge using the 250-gram bomb, liner, charge composition, and heating cycle as described is from 100 grams to 300 grams of metal.

The same technique as described above was found to give satisfactory reductions of UCl_3 with Ca 0.2 mole I_2 /mole U being used in the charge.

3. 500-Gram Scale Reductions

The bombs, liners, and heating cycle for this scale of reduction have been described. The optimum charge was found to be 0.2 mole I_2 /mole U with 25% excess Ca over that required to react with the fluoride and iodine. The scale-range of the reduction charge using the 500 gram bomb, liner, charge composition, and heating cycle as described is from 250 to 600 grams of metal.

The average yield for the 500-gram-scale reduction using the standard procedure as outlined was 99.8%. An average analysis of the metal obtained from M.I.T. liners was as follows (values in ppm): Li, <5.0; Be, <0.2; B, 0.2; Na, <5; Mg, 7; Al, <5; Si, 20; Fe, 15; C, 100; Ca, <20. Metal made on this scale using CM-7 liners ran 0.2 to 2 ppm of B. Fig. 15 is a photograph of a 500-gram button.

4. 1000-Gram-Scale Reductions

The bomb, liners, and heating cycle for this scale of reduction have been discussed. The optimum charge was found to be 0.1 mole I_2 /mole U with 25% excess Ca over that required to react with the fluoride and iodine. The scale-range of the reduction charge using the 1000-gram bomb, liner, charge composition, and heating cycle as described is from 500 to 1300 grams of metal.

UNCLASSIFIED

UNCLASSIFIED

SECRET

The average yield for the 1000-gram-scale reduction as outlined was 99.8%. An average analysis of the metal obtained from M.I.T. liners was as follows (values in ppm): Li, <0.2; Be, <0.05; B, 0.22; Na, < 5; Mg, 12; Al, < 5; Si, 58; Fe, 15; C, 120; Ca < 20. Fig. 16 is a photograph of a 1000-gram button.

UNCLASSIFIED

SECRET

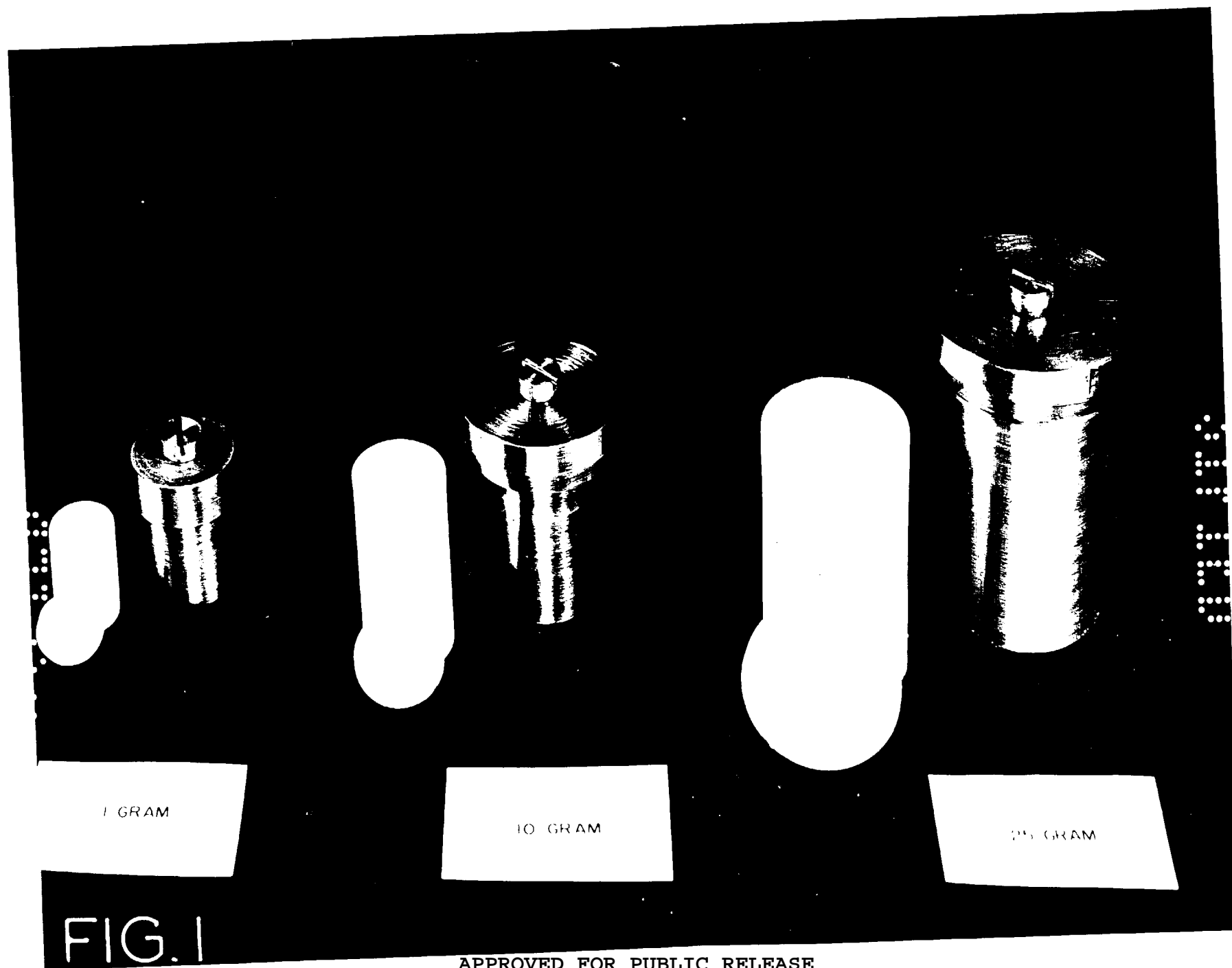

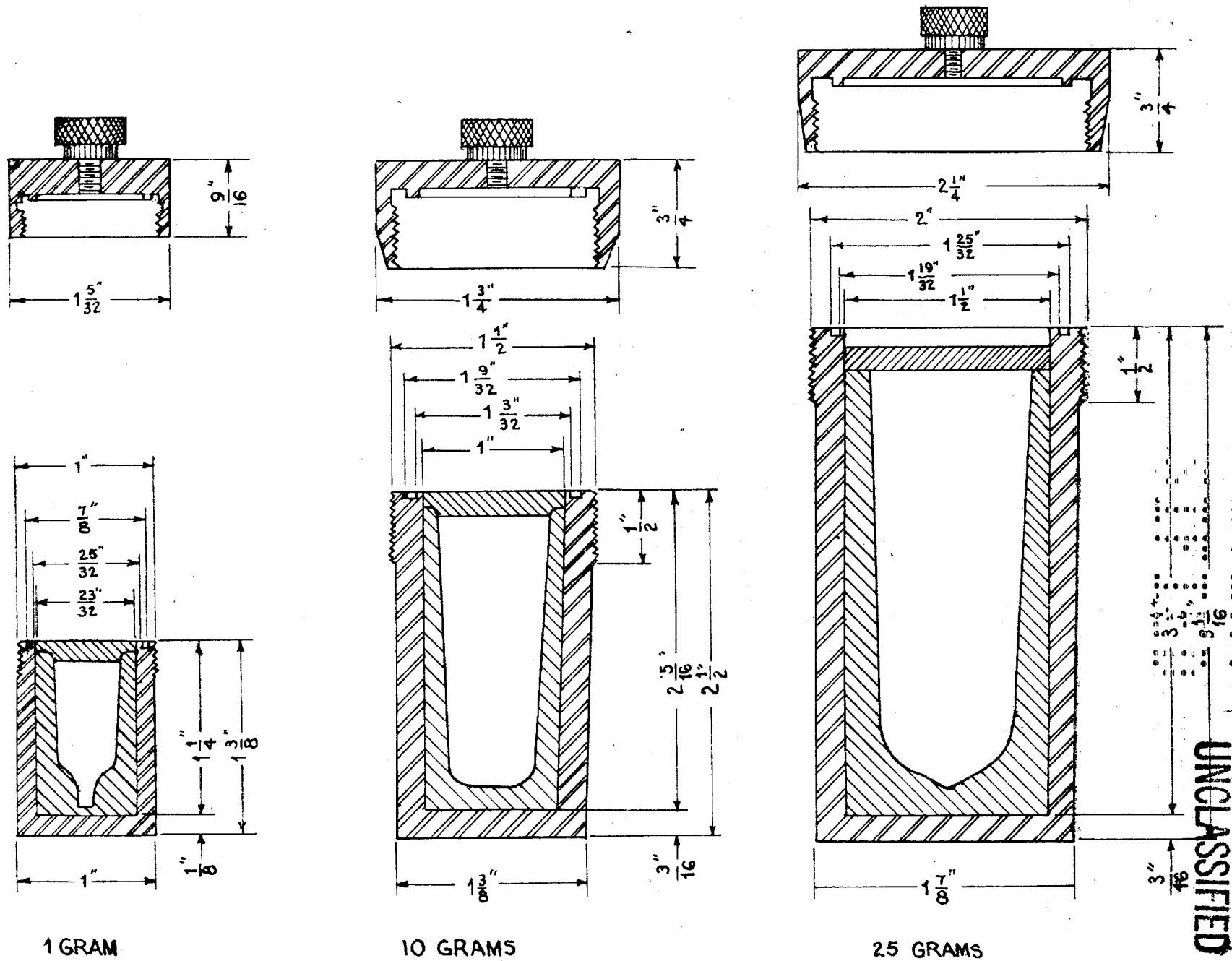

UNCLASSIFIED

UNCLASSIFIED

FIG. 2

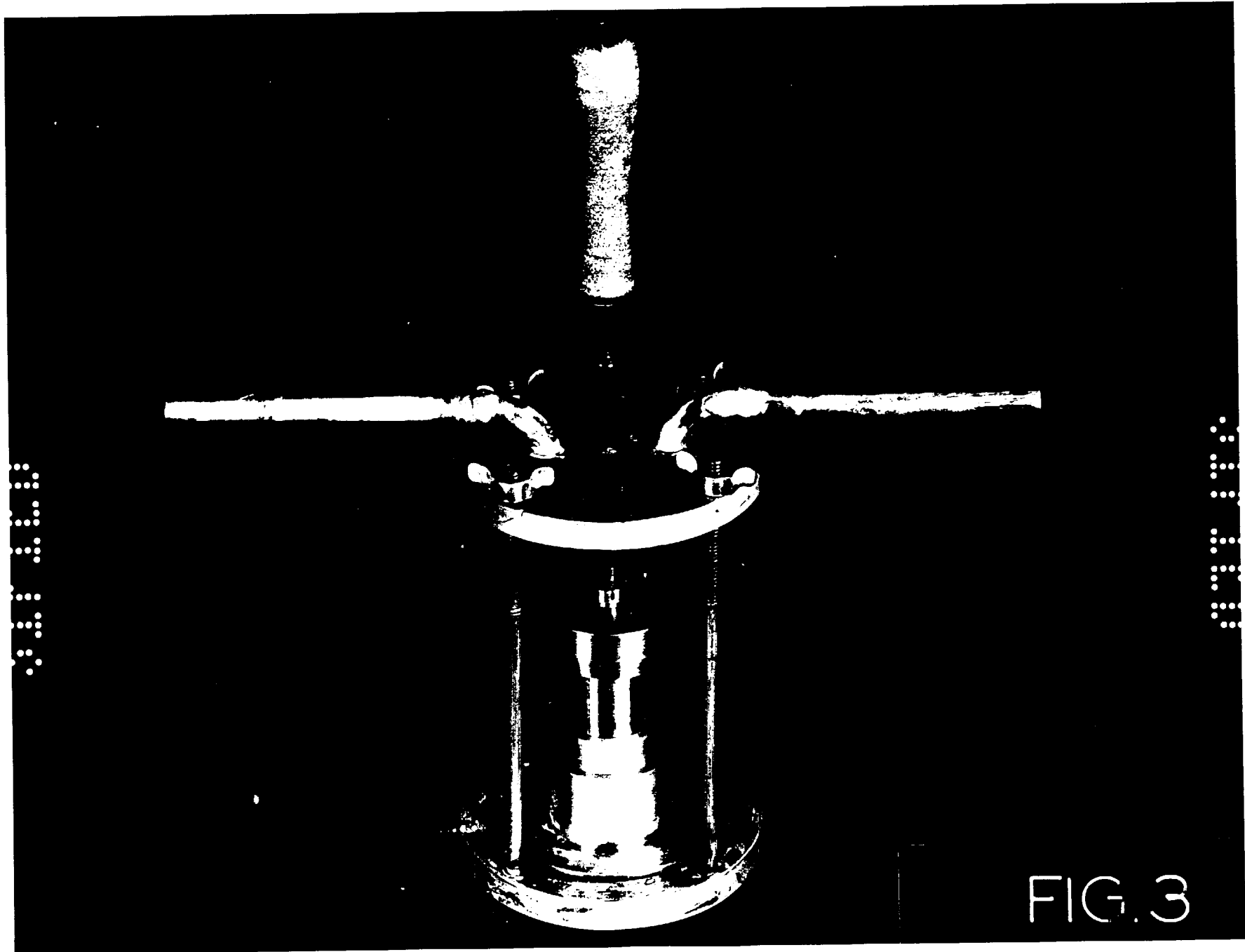
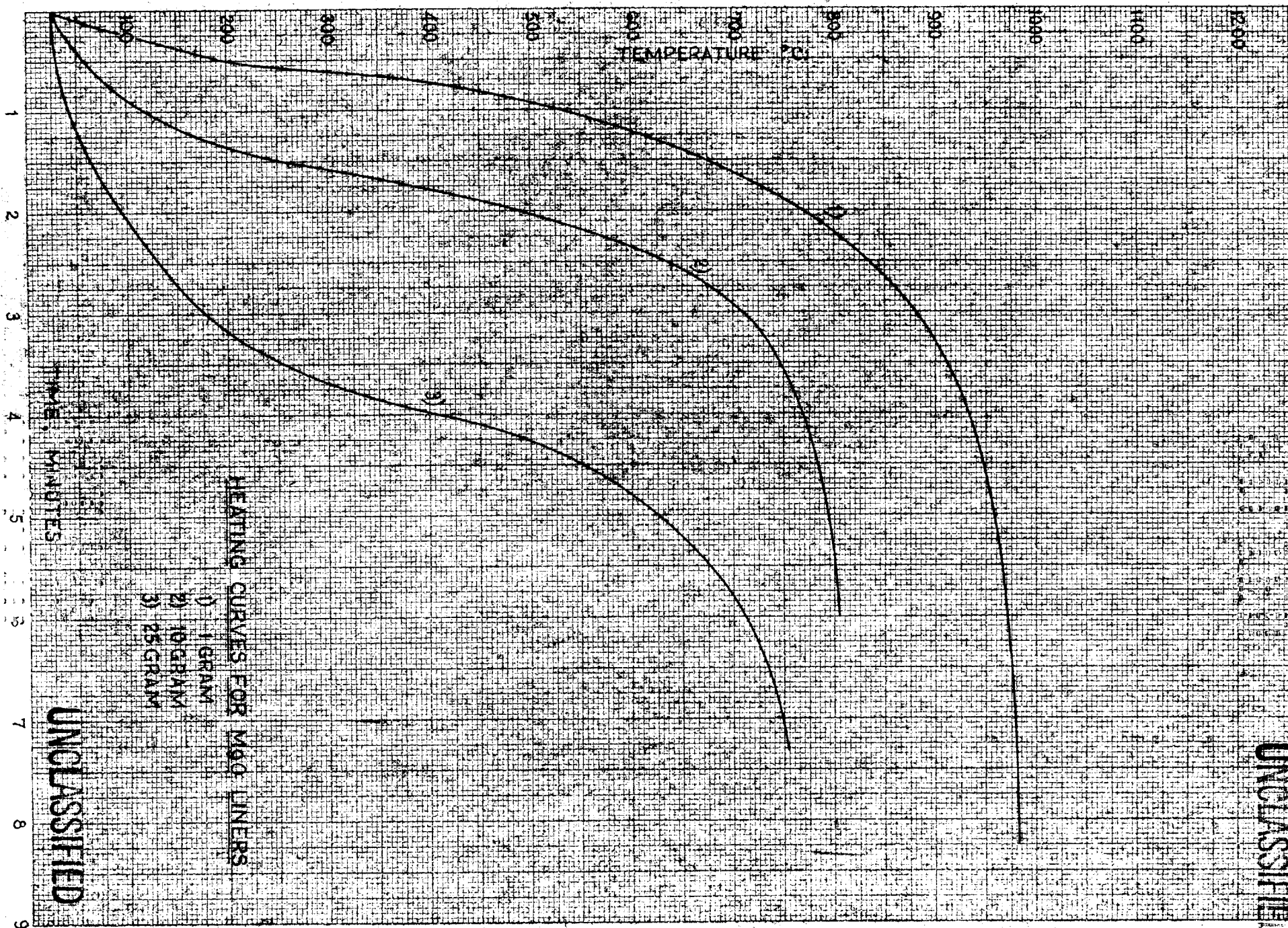

FIG. 3

MADE IN U. S. A.



HEATING CURVES FOR MgO LINERS

- 1) 1 GRAM
- 2) 10 GRAM
- 3) 25 GRAM

UNCLASSIFIED

UNCLASSIFIED

FIG. 4

1 gram

10 gram

25 gram

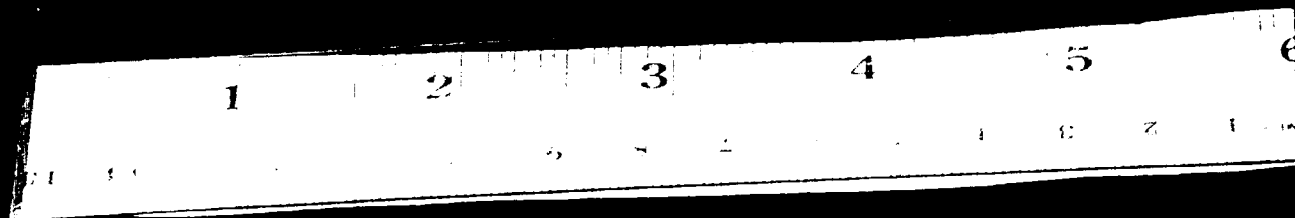
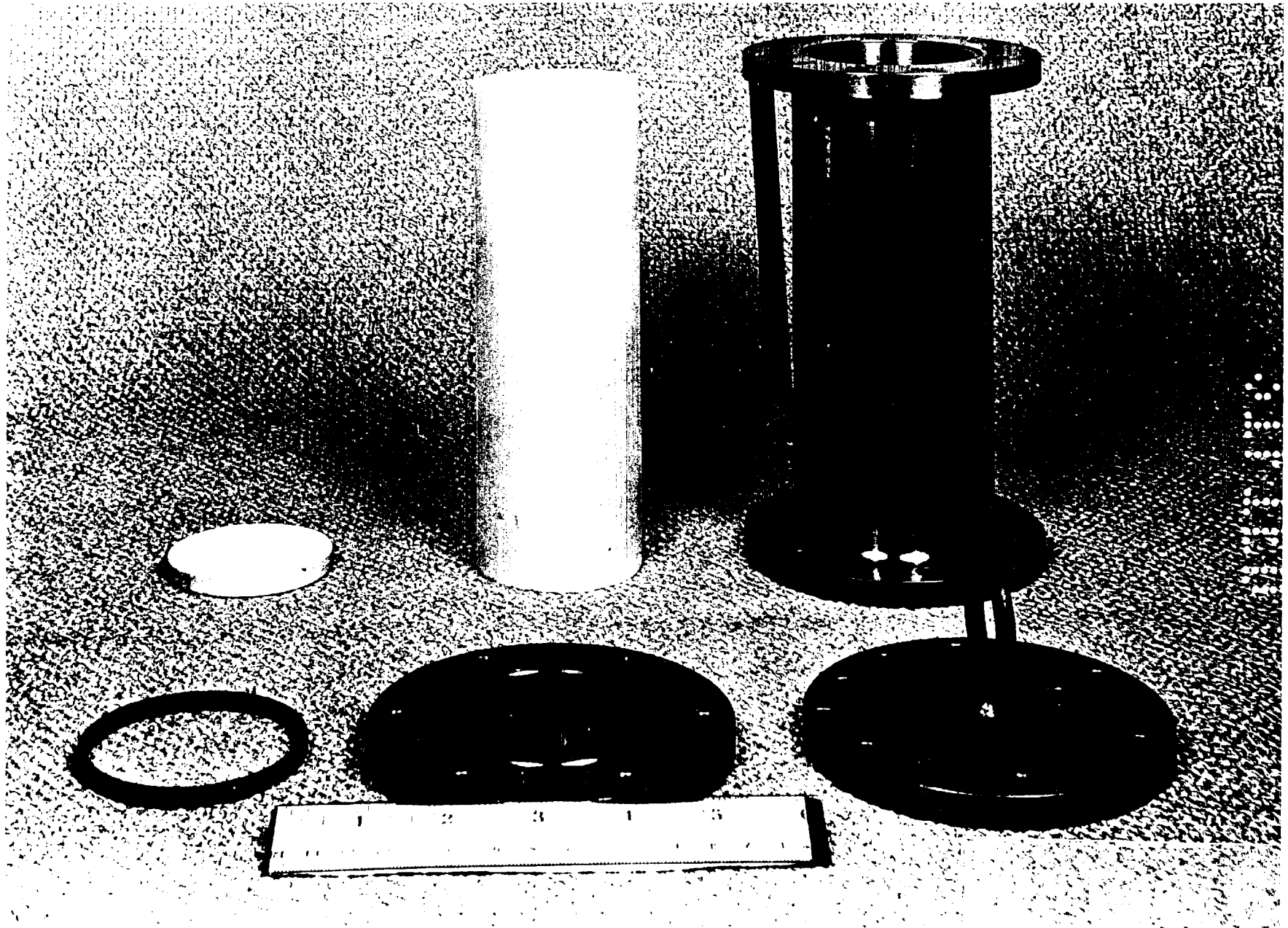
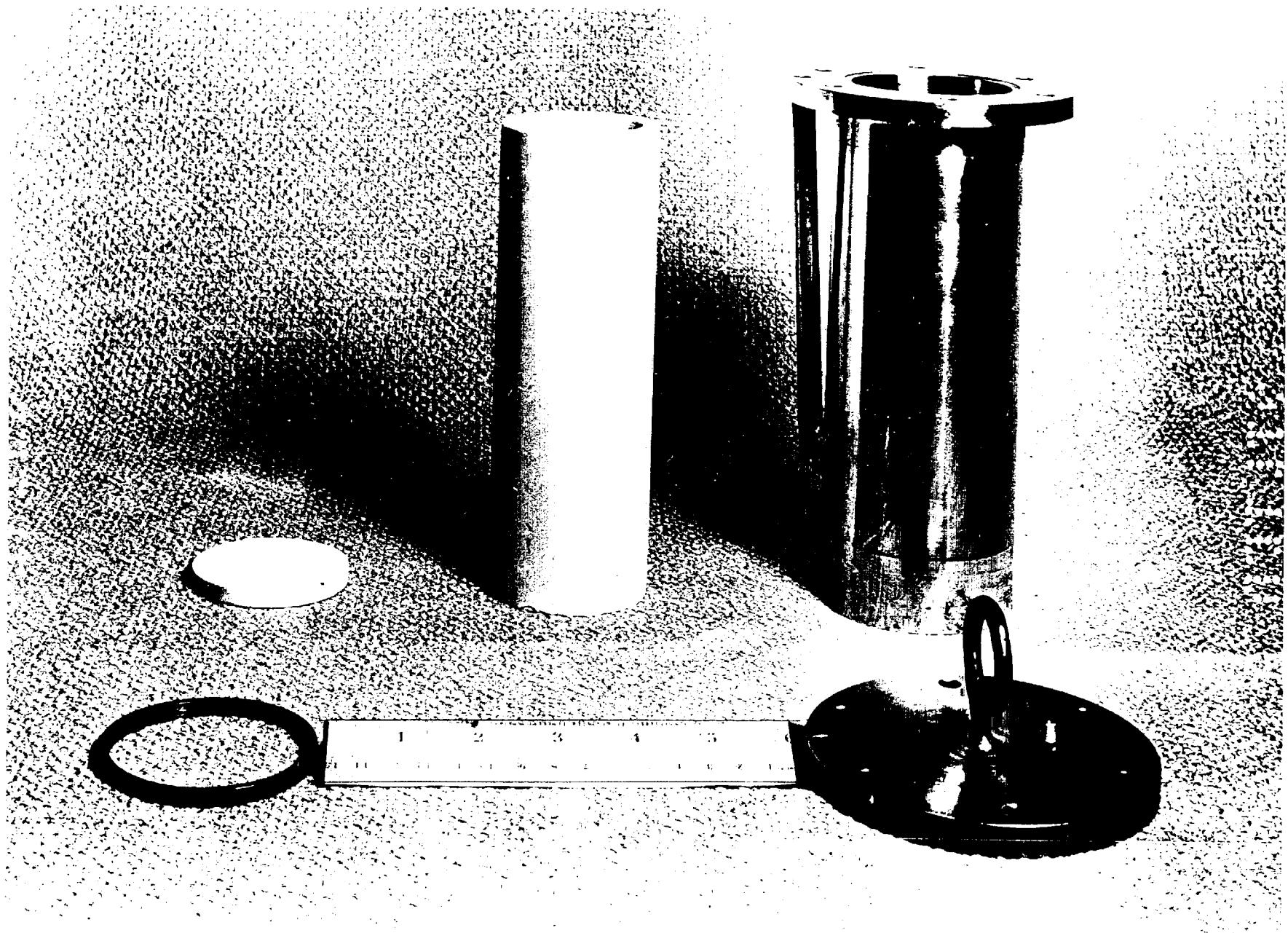

FIG. 5





UNCLASSIFIED

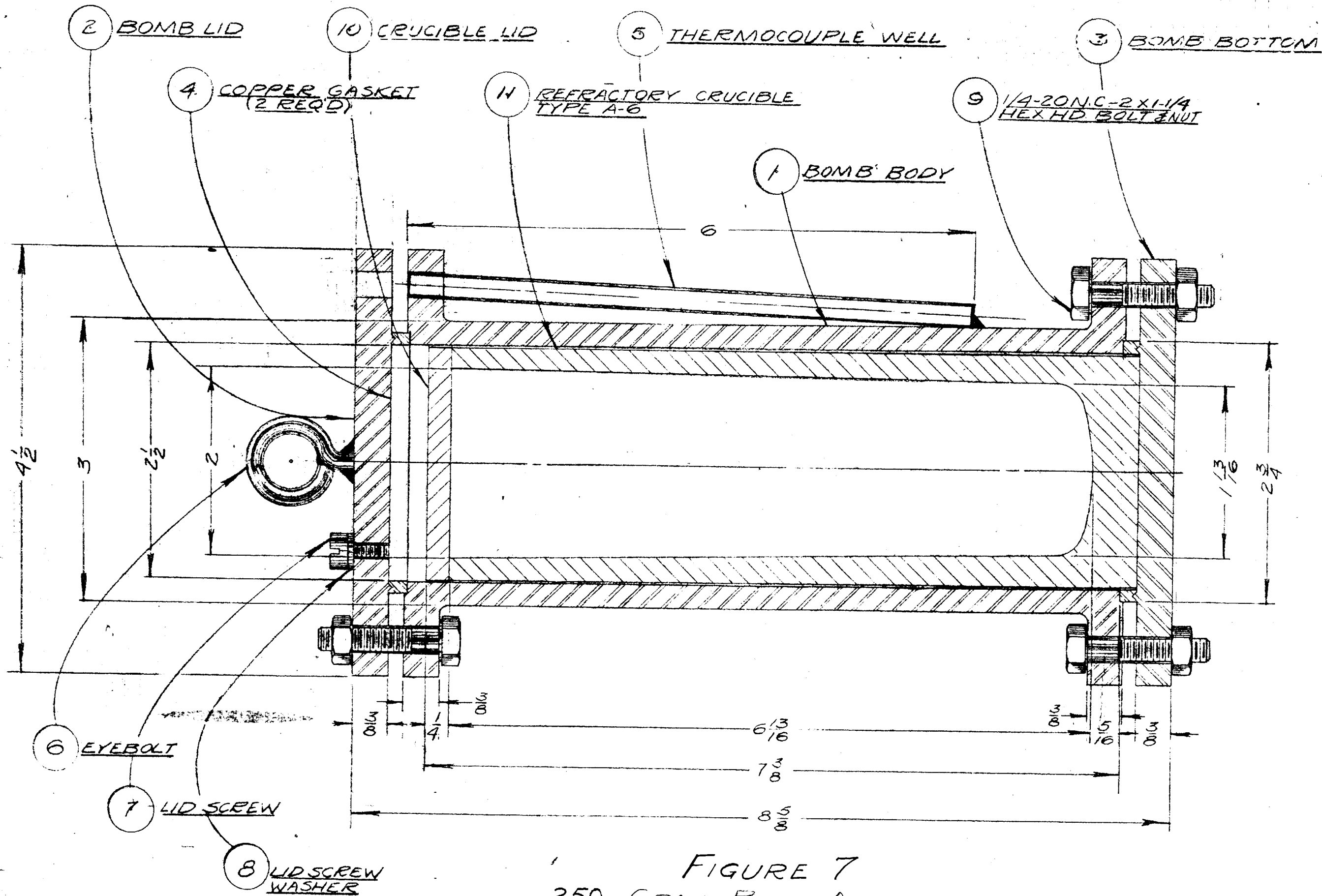

FIGURE 7
 250 GRAM BOMB ASSEMBLY
 APPROVED FOR PUBLIC RELEASE

UNCLASSIFIED

UNCLASSIFIED

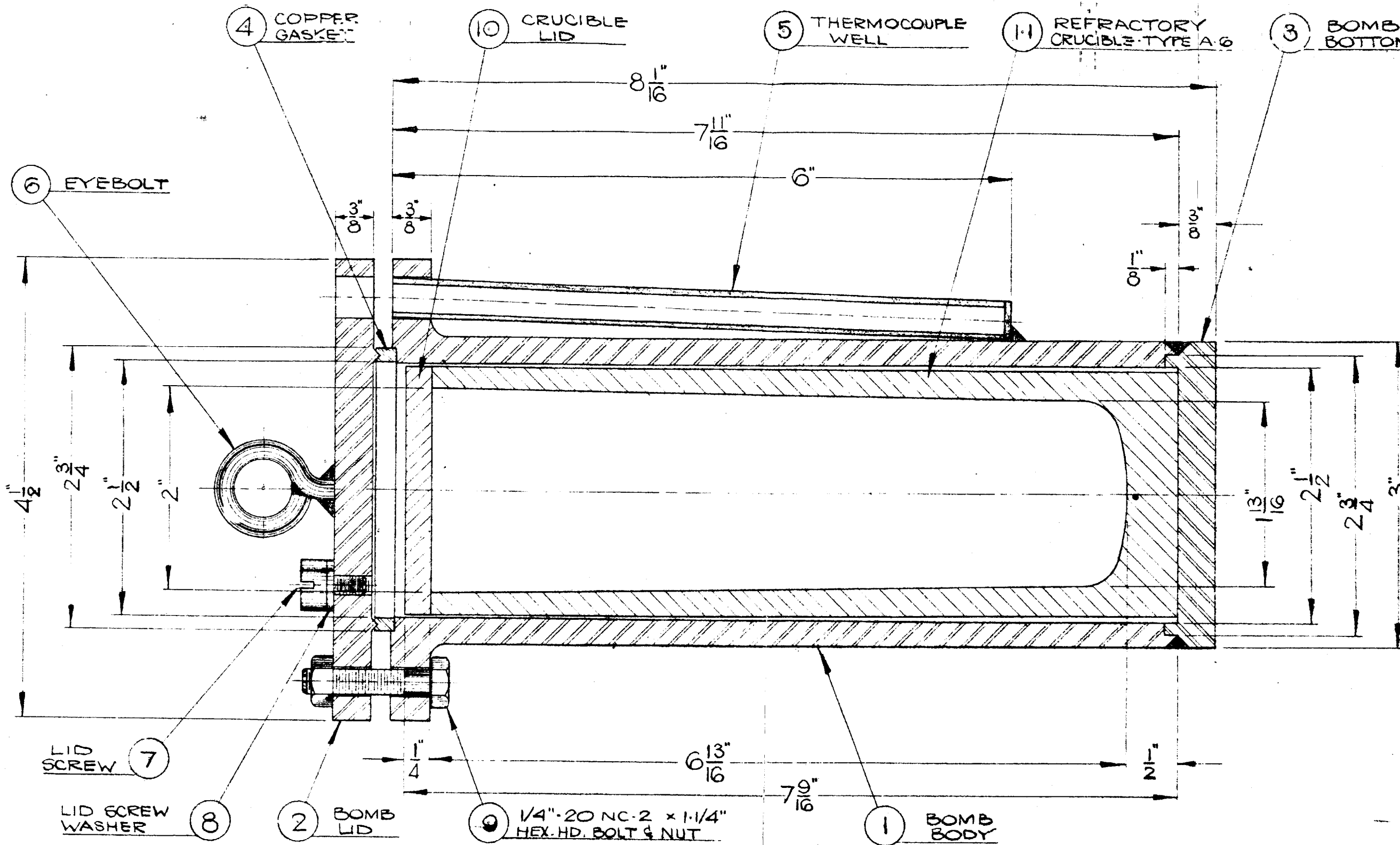
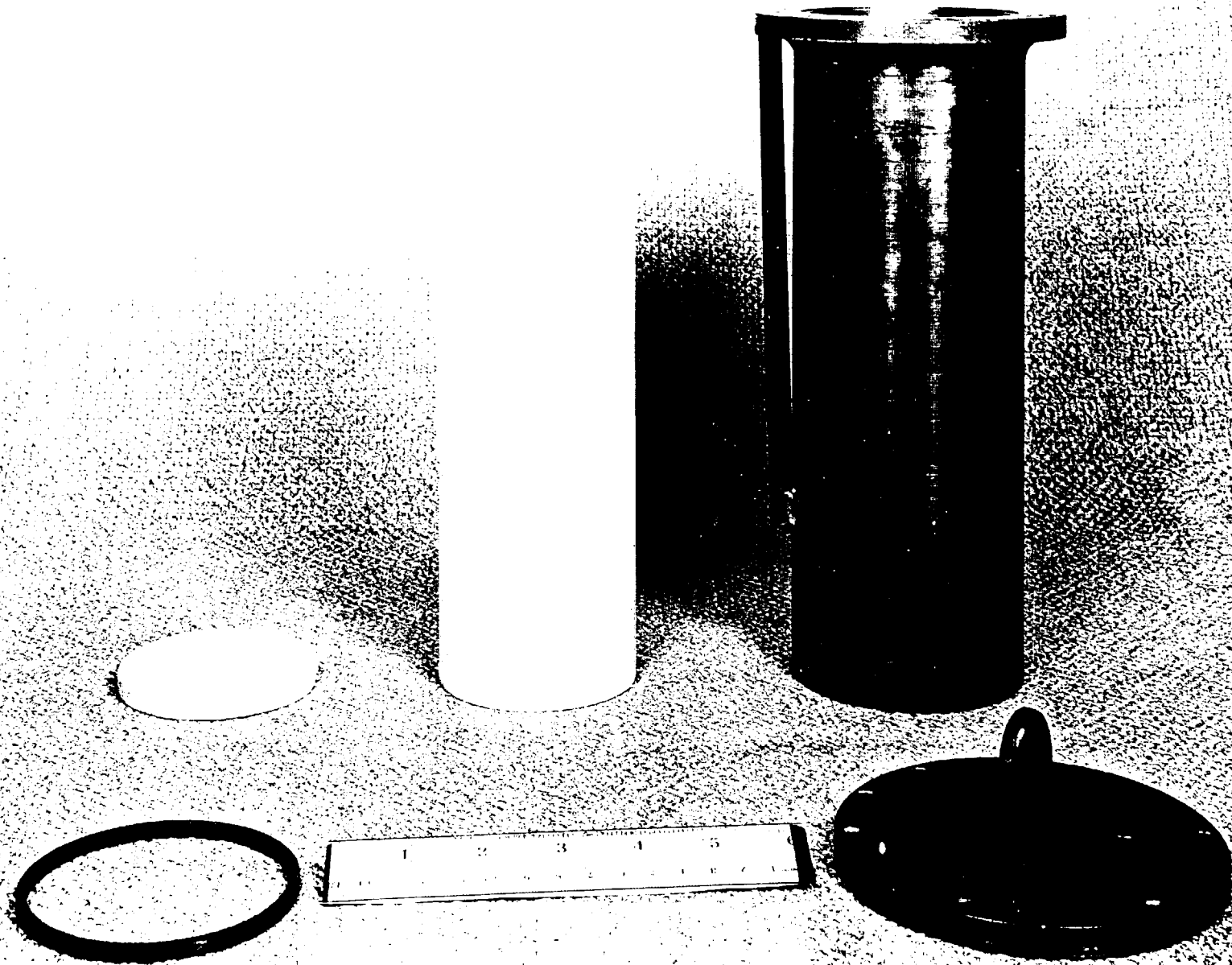

FIGURE 7(a)
250 GRAM BOMB ASSEMBLY
SCALE : FULL SIZE

UNCLASSIFIED

APPROVED FOR PUBLIC RELEASE



APPROVED FOR PUBLIC RELEASE

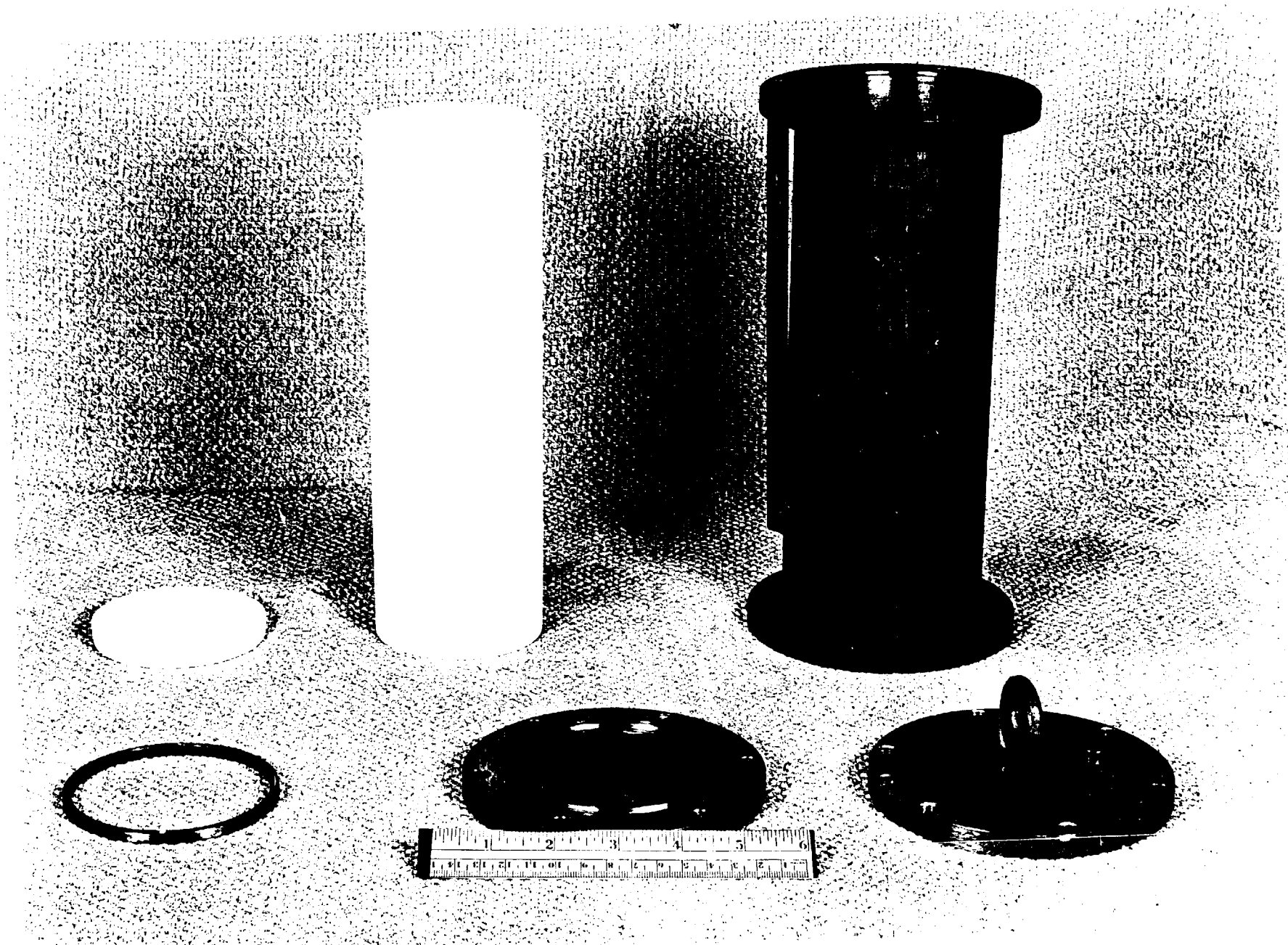

UNCLASSIFIED

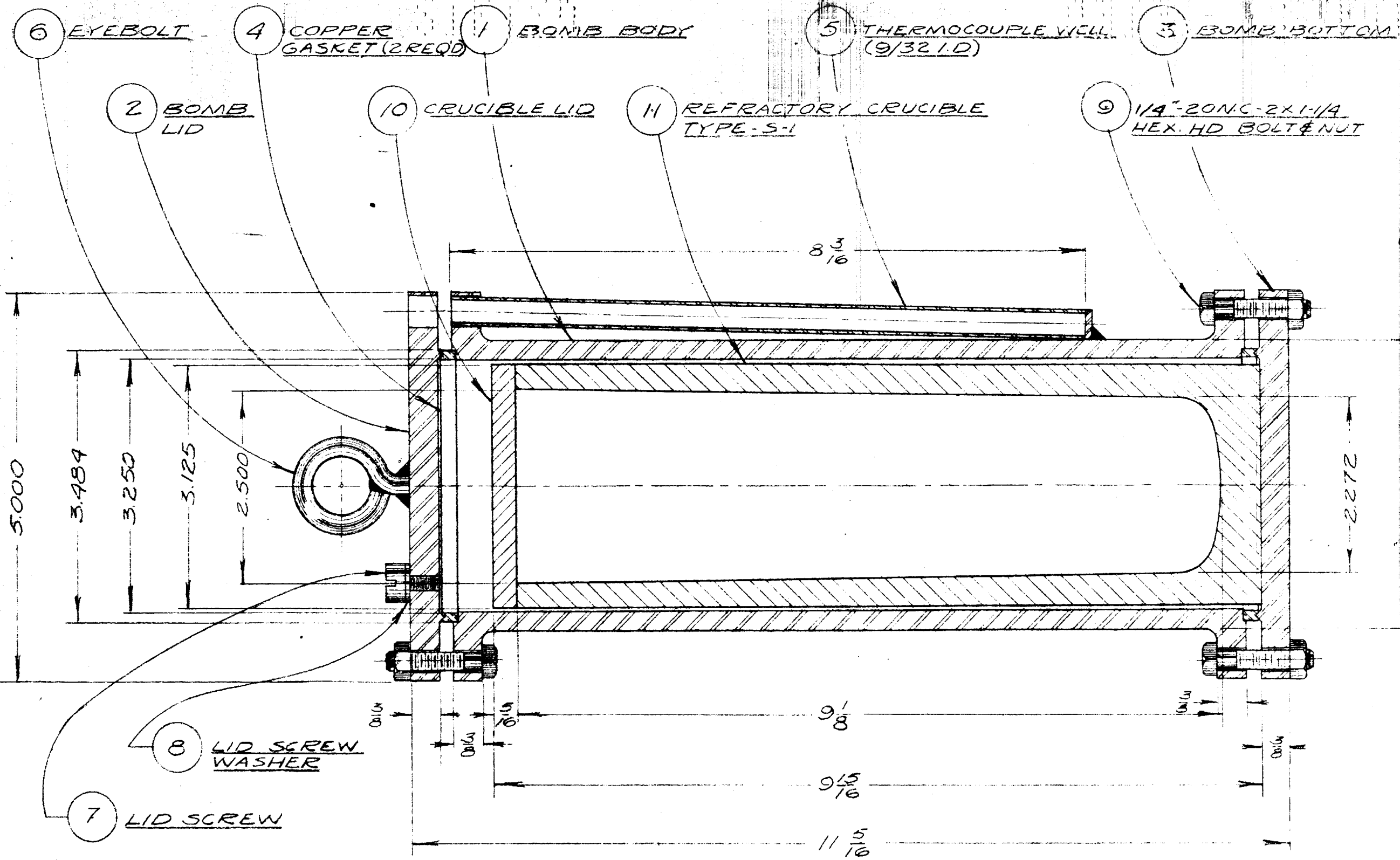

FIGURE 9
500 GRAM BOMB ASSEMBLY

UNCLASSIFIED

UNCLASSIFIED

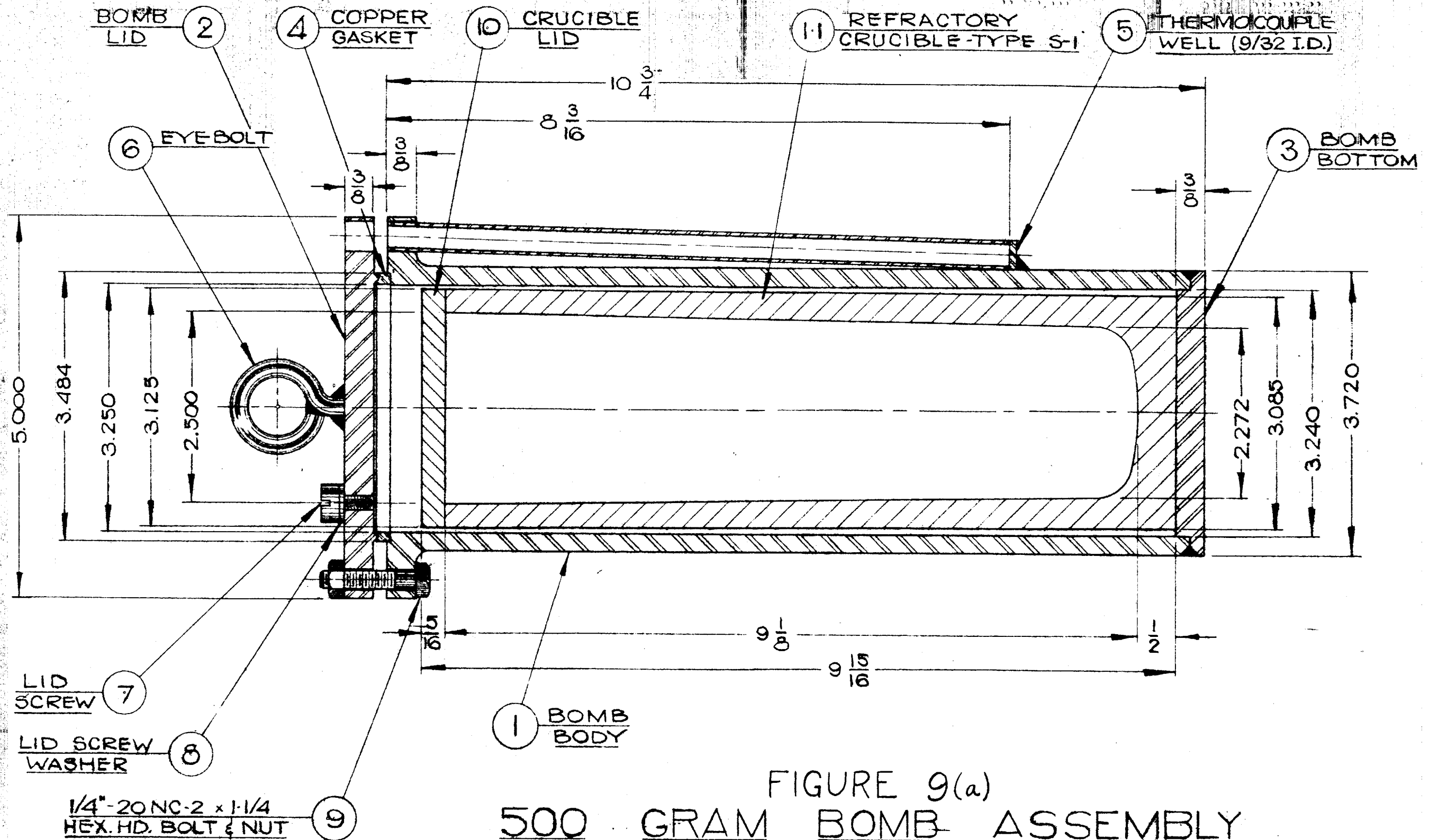
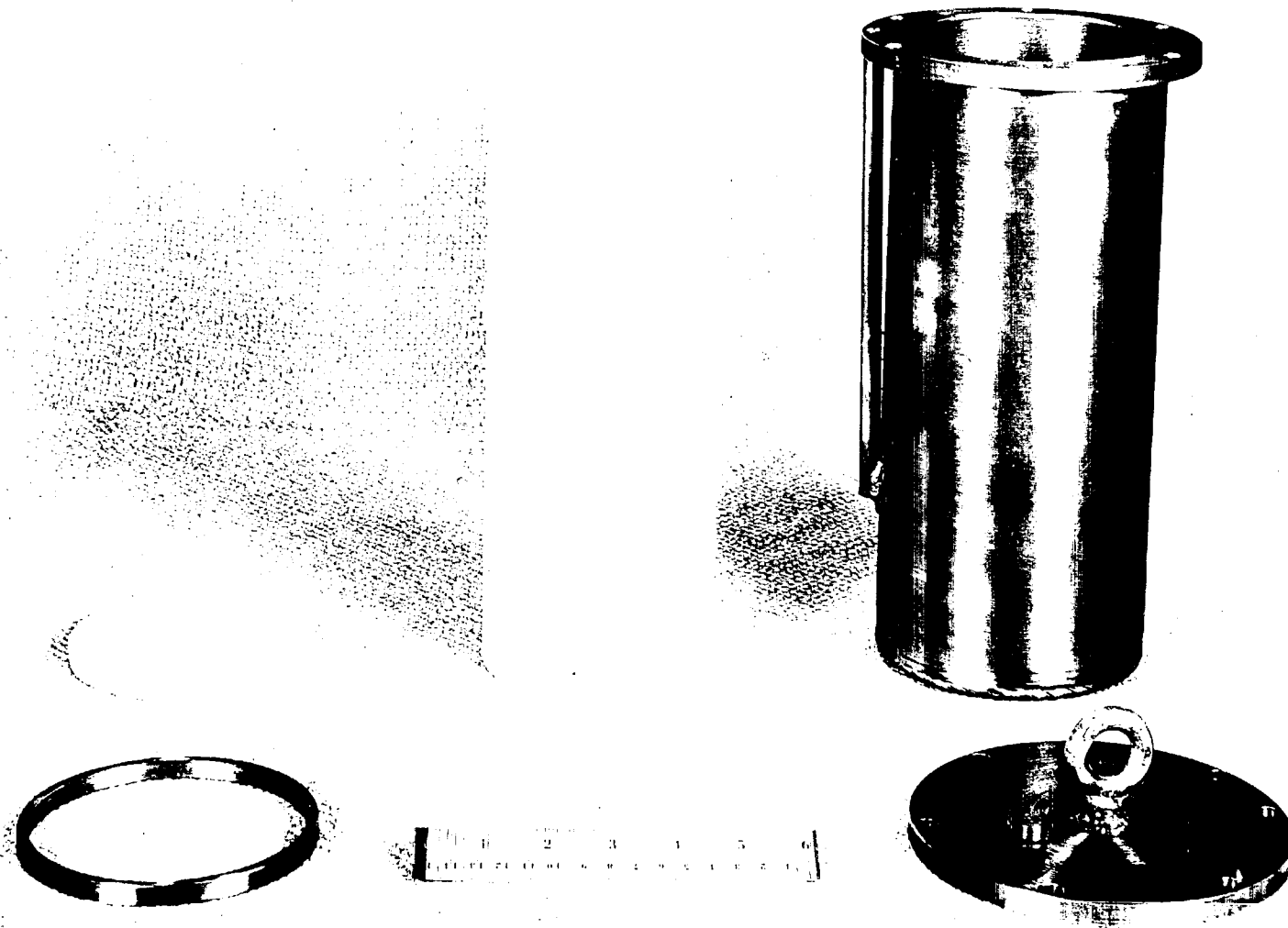

FIGURE 9(a)
 500 GRAM BOMB ASSEMBLY
 SCALE: 3/4" = 1"

UNCLASSIFIED

APPROVED FOR PUBLIC RELEASE



APPROVED FOR PUBLIC RELEASE

UNCLASSIFIED

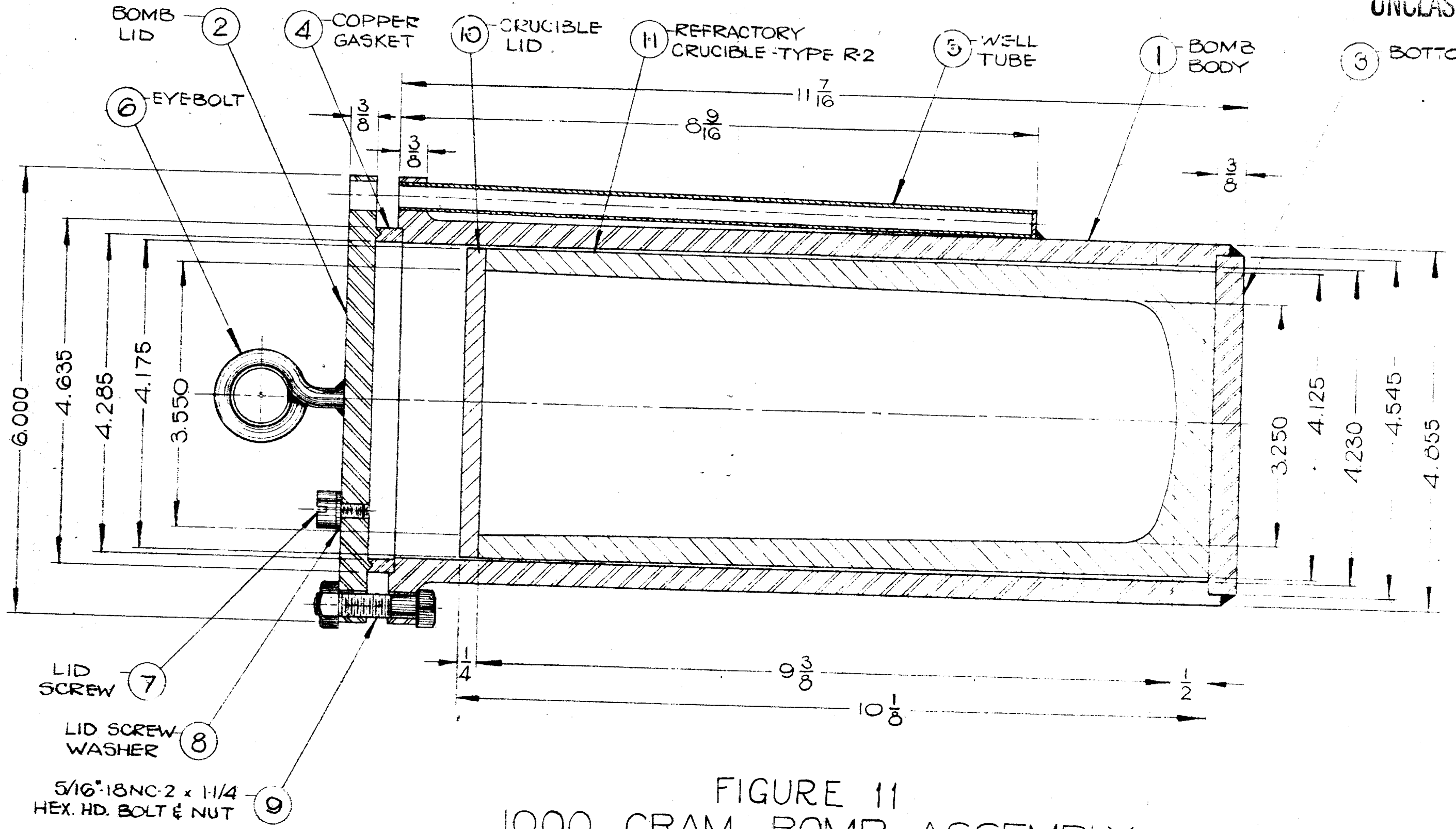
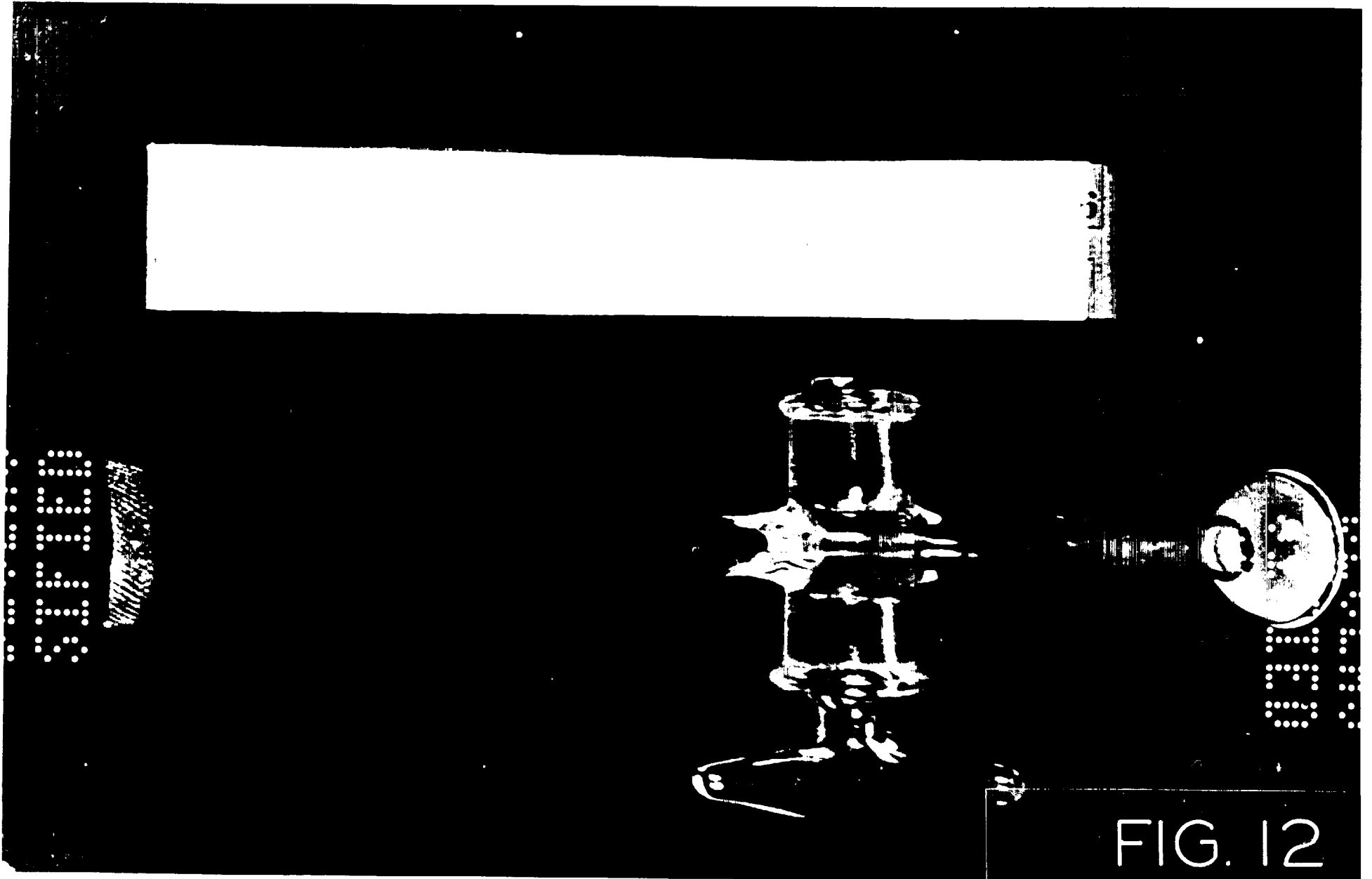

FIGURE 11
 1000 GRAM BOMB ASSEMBLY
 SCALE: 3/4" EQUALS 1"

UNCLASSIFIED





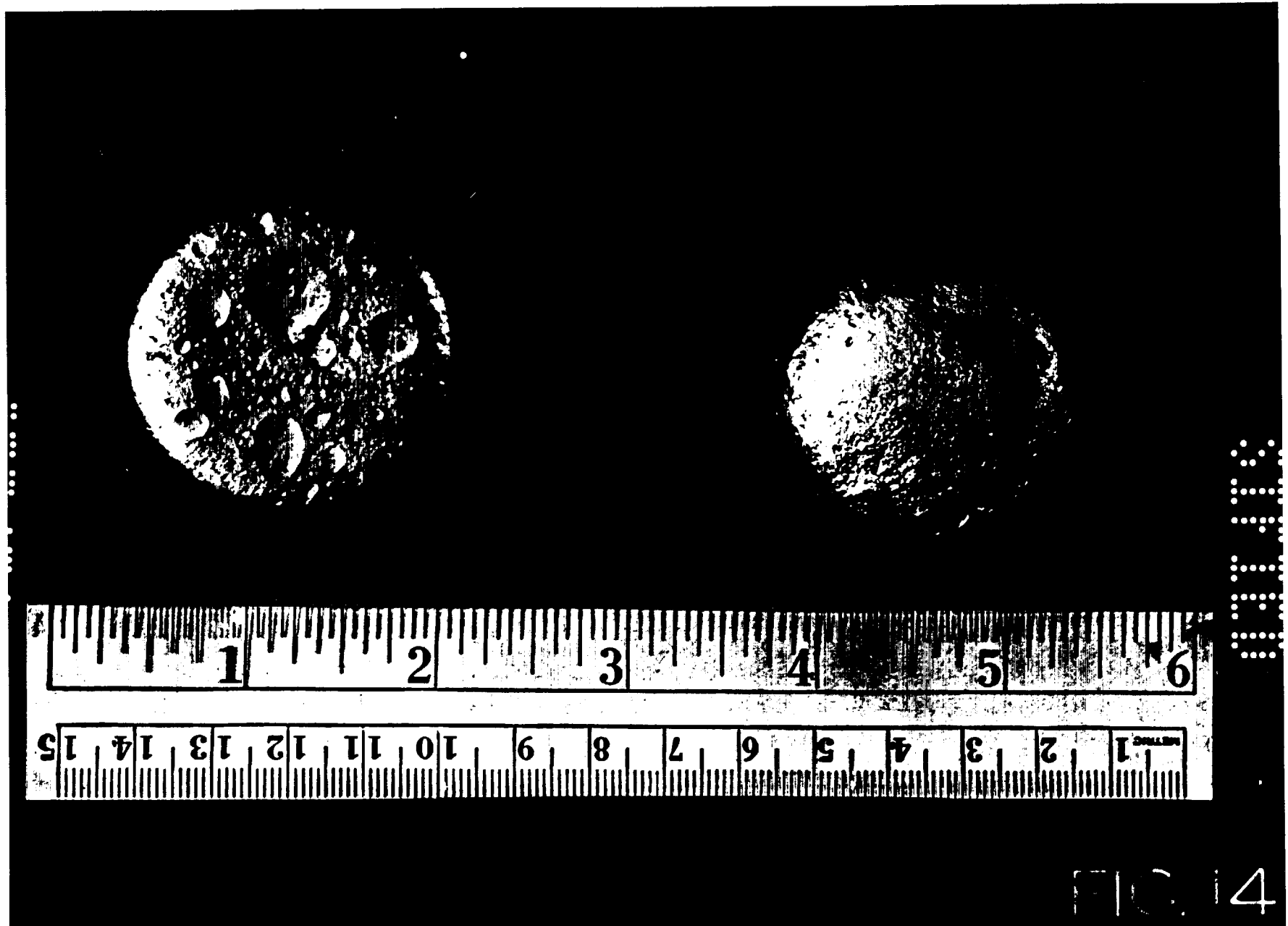

FIG. 14

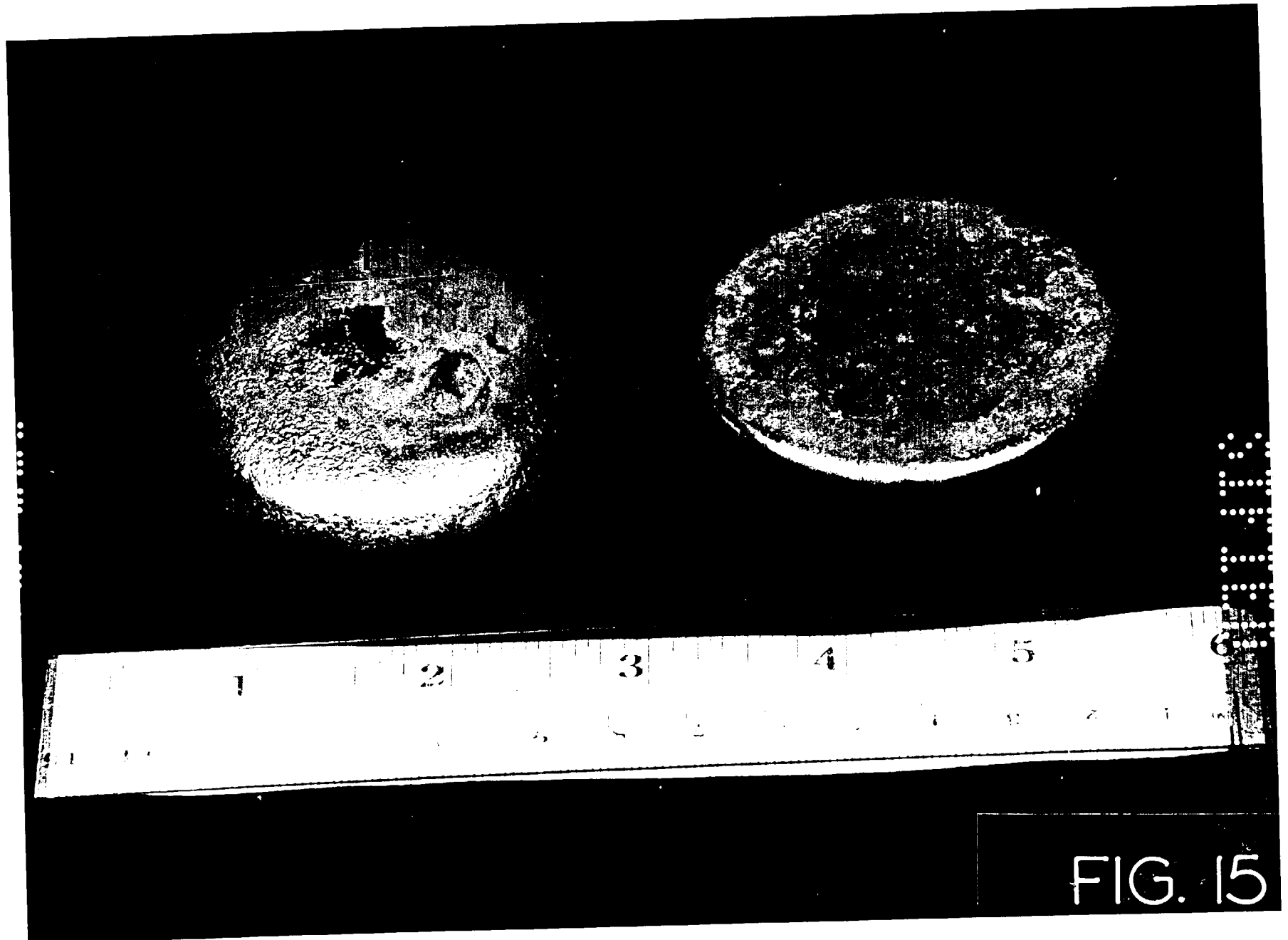

FIG. 15

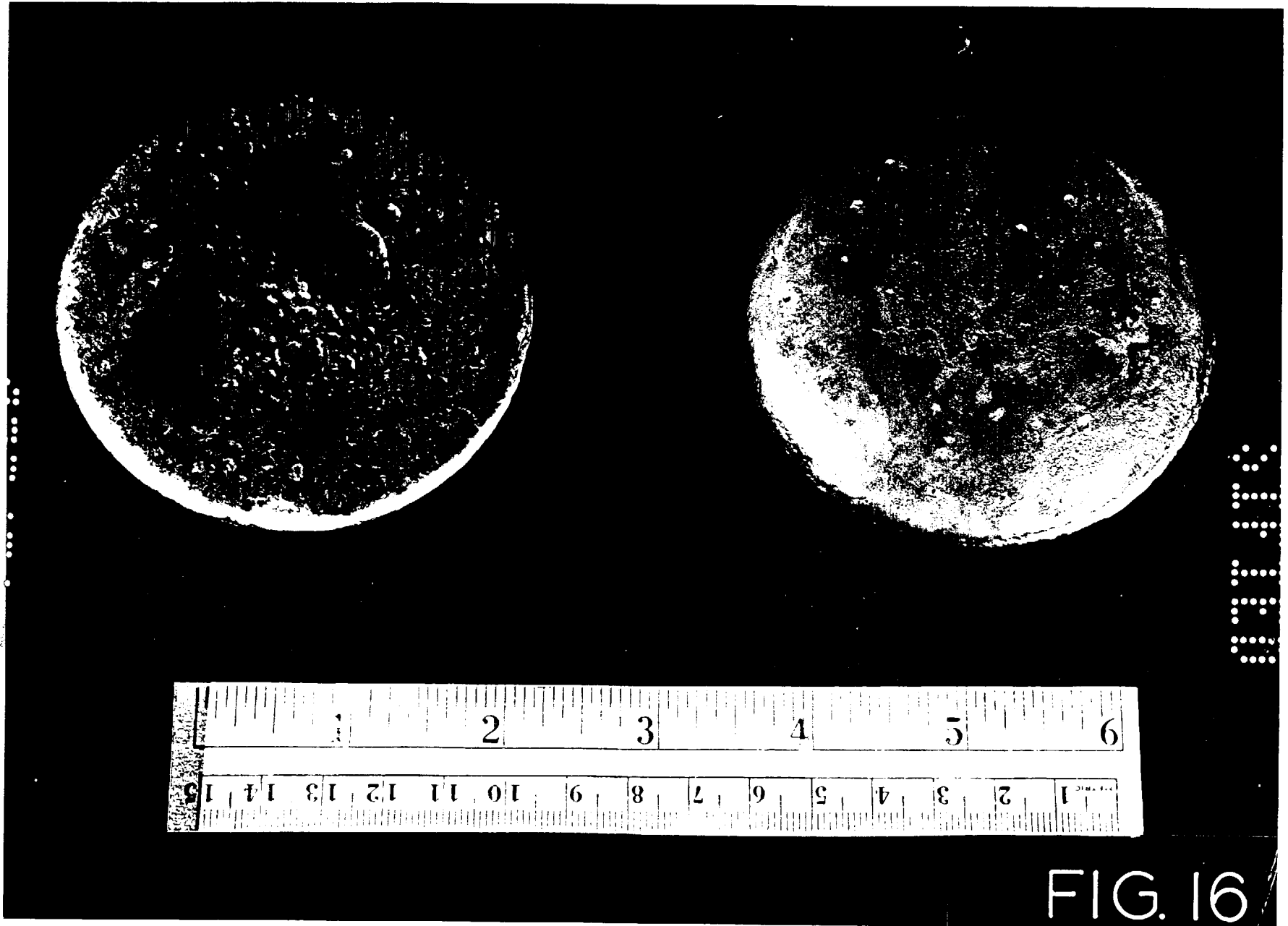

FIG. 16